

# DRIP IRRIGATION MANAGEMENT



Division of Agricultural Sciences  
UNIVERSITY OF CALIFORNIA

PRINTED OCTOBER 1981

LEAFLET 21259e

To order or obtain ANR publications and other products, visit the ANR Communication Services online catalog at <http://anrcatalog.ucanr.edu/> or phone 1-800-994-8849. You can also place orders by mail or FAX, or request a printed catalog of our products from

University of California  
Agriculture and Natural Resources  
Communication Services  
1301 S. 46th Street  
Building 478 - MC 3580  
Richmond, CA 94804-4600  
Telephone 1-800-994-8849  
510-665-2195  
FAX 510-665-3427  
E-mail: [anrcatalog@ucanr.edu](mailto:anrcatalog@ucanr.edu)

©1981 The Regents of the University of California. This work is licensed under the Creative Commons Attribution-NonCommercial-NoDerivatives 4.0 International License. To view a copy of this license, visit <http://creativecommons.org/licenses/by-nc-nd/4.0/> or send a letter to Creative Commons, PO Box 1866, Mountain View, CA 94042, USA.

Publication 21259e  
ISBN-13: 978-1-60107-960-2

The University of California, Division of Agriculture and Natural Resources (UC ANR) prohibits discrimination against or harassment of any person in any of its programs or activities on the basis of race, color, national origin, religion, sex, gender, gender expression, gender identity, pregnancy (which includes pregnancy, childbirth, and medical conditions related to pregnancy or childbirth), physical or mental disability, medical condition (cancer-related or genetic characteristics), genetic information (including family medical history), ancestry, marital status, age, sexual orientation, citizenship, status as a protected veteran or service in the uniformed services (as defined by the Uniformed Services Employment and Reemployment Rights Act of 1994 [USERRA]), as well as state military and naval service.

UC ANR policy prohibits retaliation against any employee or person in any of its programs or activities for bringing a complaint of discrimination or harassment. UC ANR policy also prohibits retaliation against a person who assists someone with a complaint of discrimination or harassment, or participates in any manner in an investigation or resolution of a complaint of discrimination or harassment. Retaliation includes threats, intimidation, reprisals, and/or adverse actions related to any of its programs or activities.

UC ANR is an Equal Opportunity/Affirmative Action Employer. All qualified applicants will receive consideration for employment and/or participation in any of its programs or activities without regard to race, color, religion, sex, national origin, disability, age or protected veteran status.

University policy is intended to be consistent with the provisions of applicable State and Federal laws.

Inquiries regarding the University's equal employment opportunity policies may be directed to: John Sims, Affirmative Action Contact and Title IX Officer, University of California, Agriculture and Natural Resources, 2801 Second Street, Davis, CA 95618, (530) 750-1397. Email: [Immanton@ucanr.edu](mailto:Immanton@ucanr.edu). Website: [http://ucanr.edu/sites/anrstaff/Diversity/Affirmative\\_Action/](http://ucanr.edu/sites/anrstaff/Diversity/Affirmative_Action/).

To simplify information, trade names of products have been used. No endorsement of named or illustrated products is intended, nor is criticism implied of similar products that are not mentioned or illustrated.

pdf-3/16-SB/CR

# CONTENTS

CHAPTER 1.	Introduction: Basic Concepts in Drip Irrigation Management	1
	E. Fereres	
CHAPTER 2.	Water and Salt Movement in Soils under Drip Irrigation	3
	R. J. Miller, J. W. Biggar, G. L. Hoffman, D. E. Rolston	
CHAPTER 3.	Crop Responses to Drip Irrigation	6
	D. W. Henderson, E. Fereres	
CHAPTER 4.	Evapotranspiration and Drip Irrigation Scheduling	8
	E. Fereres, W. O. Pruitt, J. A. Beutel, D. W. Henderson, E. Holzapfel, H. Schulbach, K. Uriu	
CHAPTER 5.	Application of Chemicals through Drip Systems	14
	R. L. Branson, H. Schulbach, R. S. Rauschkolb, J. M. Ribble	
CHAPTER 6.	Clogging and Filtration in Drip Irrigation	20
	J. M. Ribble, J. L. Meyer, F. K. Aljibury, H. Schulbach	
CHAPTER 7.	Aspects of Drip Irrigation Components—Design and Evaluation	25
	H. Schulbach, E. Fereres, B. R. Hanson, J. L. Meyer, F. K. Aljibury	
CHAPTER 8.	Other Methods of Localized Irrigation	33
	S. L. Rawlins	
CHAPTER 9.	Drip Irrigation of Avocados in San Diego County: A Case Study	36
	C. D. Gustafson, A. W. March, R. L. Branson, S. A. Davis	
REFERENCES		39

# **DRIP IRRIGATION MANAGEMENT**

**ELIAS FERERES, TECHNICAL EDITOR**

## **THE AUTHORS**

**F. K. Aljibury**, Former Area Soil and Water Specialist, Cooperative Extension, Parlier

**J. A. Beutel**, Pomologist, Cooperative Extension, Davis

**J. W. Biggar**, Professor, Department of Land, Air and Water Resources, Davis

**R. L. Branson**, Soils and Water Specialist, Cooperative Extension, Riverside

**S. Davis**, Former USDA SEA-AR, Riverside

**E. Fereres**, Irrigation and Surface Water Specialist, Cooperative Extension, Davis

**C. D. Gustafson**, Farm Advisor, Cooperative Extension, San Diego County

**B. R. Hanson**, Drainage and Groundwater Specialist, Cooperative Extension, Davis

**D. W. Henderson**, Professor, Department of Land, Air and Water Resources, Davis

**G. L. Hoffman**, USDA-SEA-AR, U.S. Salinity Laboratory, Riverside

**E. Holzapfel**, Former Graduate Student, Department of Land, Air and Water Resources, Davis

**J. L. Meyer**, Unit Director and Irrigation and Soils Specialist, Cooperative Extension, Riverside

**A. W. Marsh**, Former Irrigation and Soils Specialist, Cooperative Extension, Riverside

**R. J. Miller**, Water Scientist, Department of Land, Air and Water Resources, Westside Field Station, Five Points

**W. O. Pruitt**, Irrigation Engineer, Department of Land, Air and Water Resources, Davis

**R. S. Rauschkolb**, Program Director, Cooperative Extension, Davis

**S. L. Rawlins**, USDA-SEA-AR, U.S. Salinity Laboratory, Riverside

**J. M. Rible**, Area Soils and Water Specialist, Cooperative Extension, Riverside

**D. E. Rolston**, Associate Professor, Department of Land, Air and Water Resources, Davis

**H. Schulbach**, Area Soils and Water Specialist, Cooperative Extension, Colusa County

**K. Uriu**, Pomologist, Department of Pomology, Davis

# Chapter 1

---

## Introduction: Basic Concepts in Drip Irrigation Management

Drip irrigation was introduced into California around 1970. Since then it has expanded rapidly to include over 150,000 acres of various fruit and vegetable crops and ornamentals currently being irrigated in the state.

Two distinct features are characteristic of the drip method: the high frequency of irrigation (daily in many cases) and localized water application to only part of the crop's potential root zone. Neither feature is unique to drip irrigation, however; permanent sprinkler systems can also apply water at frequent intervals without increased labor costs, and localized irrigation is frequently done when establishing a new orchard by running two furrows, one on each side of the young tree. Nevertheless, high-frequency, localized irrigation makes operation and management of drip systems basically different than that of conventional irrigation methods.

Because of the significant acreage currently irrigated by drip in California and the probability of its expansion, this publication emphasizes the water management aspects of drip irrigation and devotes less space to system description and engineering design problems.

Understanding the basic principles that determine the movement of water and salts under drip irrigation (Chapter 2) is necessary for efficient water management and salinity control. Long-term success of the drip irrigation method in areas of California where winter rainfall is insufficient for leaching will depend on careful monitoring of the water and salt content in the crop root zone.

Crops respond more to soil water levels and irrigation regime than to method of irrigation, despite effects unique to certain methods. Therefore, results of research with other irrigation methods are applicable to drip in determining proper irrigation management. Crop responses to drip irrigation are discussed in Chapter 3.

The amount of water that can be saved by changing to drip depends on the efficiency of the method that the grower has been using. However, there will be some savings due to a reduction in evaporation from the soil in addition to any increase in irrigation efficiency. The magnitude of such savings is still a subject of research but presumably is directly related to the degree of plant cover (see Chapter 4).

Appropriate drip irrigation scheduling should be the central aspect of good water management (Chapter 4). Enough data now exist on crop water requirements that good estimates of consumptive use can be made in many areas of California. Such estimates can be checked initially by monitoring the soil water conditions using neutron probes, tensiometers, or, more simply, a soil auger.

Changing the method of irrigation is to a large extent an economic decision. (See Leaflet 2875, "Irrigation Costs," available at your local county office of the University of California Cooperative Extension, for procedures to calculate the annual costs of various irrigation systems including drip.) But because of the rapid changes in prices and equipment availability, economics of drip systems are not dealt with directly in this publication. However, questions frequently asked by growers who may be considering a change to drip irrigation are discussed and answered based on research data and our current knowledge of crop/water relations.

The localized wetting patterns produced by drip systems may present limitations to crop nutrient uptake. It is, therefore, imperative under drip irrigation to combine irrigation with fertilization by injecting fertilizers through the drip system. Chapter 5 emphasizes the practical aspects of nutrient application in drip irrigation.

The features that make drip irrigation so desirable are also the cause of its most severe disadvantage. The convenient low flow rates and the small-diameter emitters for better water control and distribution favor the accumulation of materials that reduce emitter output and can eventually clog the system completely. The clogging problem is so widespread that it is a rare and fortunate owner of a drip system who has not experienced some type of clogging problem. Chapter 6 provides guidelines for preventing clogging by selecting appropriate filtration equipment as well as techniques for correcting clogging problems by injecting various chemicals (depending on the nature of the clogging agent).

Chapter 7 gives a brief description of the drip irrigation system components and discusses aspects of functional design, including an example using microtube emitters which are popular among small growers because of their flexible discharge rates and low cost.

One way of reducing clogging in conventional drip systems is to increase the diameter of emitter openings. That approach has given rise to a number of devices such as foggers, misters, spitters, and so on which apply water to a larger area (3 to 10 feet in diameter) than conventional drip emitters. Such methods and a bubbler method are presented in Chapter 8 as other methods of localized irrigation that are becoming increasingly popular in California.

Drip irrigation in California was first introduced in the avocado groves of San Diego County. Adaptive research was badly needed to develop guidelines for its use and was conducted by University of California Cooperative Extension. Chapter 9 describes the results of five years of research to determine the effects of drip irrigation on avoca-

does—research that was instrumental in the success of the drip method in the steep hills of San Diego County.

Drip irrigation has opened marginal lands to agricultural production in arid zones of the world where the climate is favorable for intensive crop production. Thus, drip systems will continue to expand in those areas where every drop of water counts.

This publication summarizes the research effort aimed at developing the information needed for successful management of drip irrigation systems. It is aimed primarily at the user, recognizing the high level of technology that many growers now have. We also hope that it will be useful to farm advisors, farm managers, and other professionals in the field of irrigation.

## Chapter 2

# Water and Salt Movement in Soils under Drip Irrigation

Where irrigation is necessary for crop production, there is also a need to deal with the problem of salt accumulation in the plant root zone. It is possible to control salinity by proper water management while still maintaining a high level of irrigation efficiency.

### Water distribution in soil

The distribution of water from drip systems may be nearly continuous along crop rows, as in porous perforated pipe or tape systems, or may be considered as point sources for widely-spaced emitters. Such localized water application patterns give rise to nonuniform distribution of irrigation water and salinity in the crop root zone. (Figure 1 depicts cross-sections of generalized soil moisture profiles under drip irrigation for equal quantities of water applied at the same rate to soils of different textures.) The rate at which water enters the dry soil and the ability of a soil to conduct or transmit water determine the soil-water distribution patterns. Such patterns, however, can be modified by changing the rate and frequency of water application. (Figure 2 shows the differences in soil-water distribution patterns for two application rates on two soils differing in their ability to conduct water.)

The rate of drip discharge and the texture of the soil have a marked effect on the shape of the wetted soil zone. Although water application rates through drip systems are considered low,

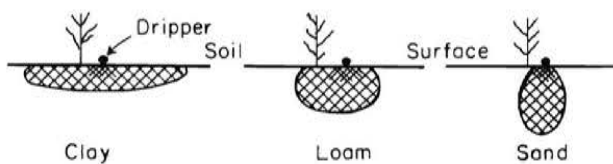

Fig. 1. Water distribution patterns under drip irrigation applied in equal quantities at the same rate as affected by soil texture. Note that the lateral spread in the case of the clay soil is due to surface ponding.

ponding around the emitter can occur under field conditions in cases where the rate of application by the emitter exceeds the ability of the soil to absorb the water. In such cases the horizontal movement of water increases as the ponded area increases in size. When the rate of water application is increased or the ability of a soil to conduct or transmit water is low, the horizontal movement of the wetting zone increases with a corresponding decrease in the vertical direction (fig. 2).

When water is applied in such a way that ponding is minimal, soil aeration would be adequate because the soil will approach saturation only near the water source.

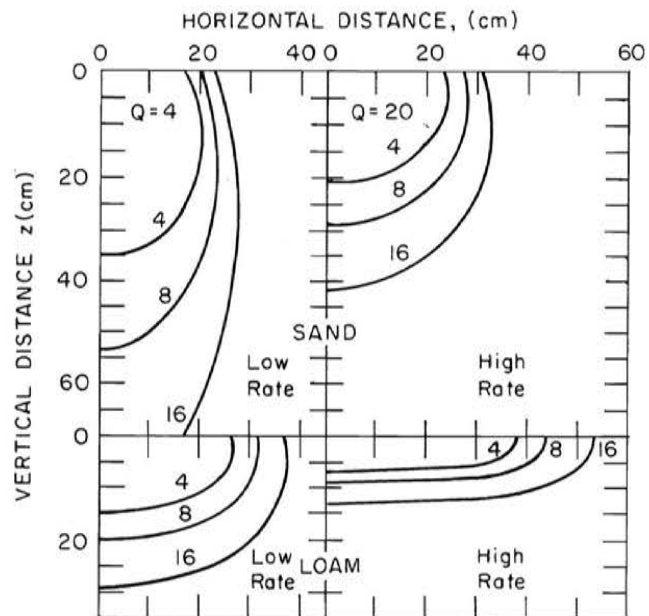

Fig. 2. Water distribution profiles in soils of two textures at two rates of water application,  $Q = 1$  and  $5$  gallons per hour ( $4$  and  $20$  liters per hour). The numbers on the curves refer to total quantities of water applied. (Redrawn from Bresler, 1977.)



Excessively high water application rate under drip irrigation results in ponding and runoff.

### Salt distribution and leaching requirements

All soils and irrigation waters contain a mixture of soluble salts which is detrimental to plant growth if concentrations of salt are excessive. While the evapotranspiration process removes large quantities of water from the soil, negligible quantities of salt are removed by plants and the salt remaining in the soil concentrates in the remaining soil water. Where irrigation water is relatively low in salt content and rainfall is adequate for leaching, irrigation need only meet the evapotranspiration demand of the crop. If the irrigation water is high in salt content or rainfall is inadequate, or both, leaching must be accomplished by additional irrigation. In the spring, after leaching by rainfall has been evaluated, preplant irrigation may be required for leaching because many crops are most sensitive to salinity during germination and early growth, and because water is more plentiful and less expensive during the spring. For perennial

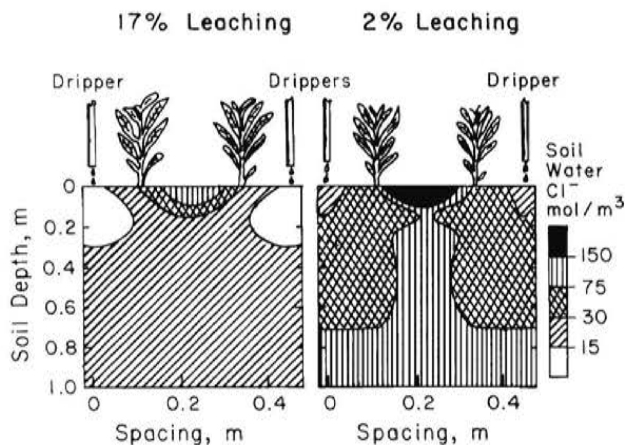

Fig. 3. The distribution of salt under a multi-emitter drip system with narrow crop rows after two years and without rainfall. Chloride concentration is the measure of salinity. (Redrawn from Hoffman *et al.*, 1979.)

crops, applying an additional amount of water for leaching during each irrigation is often most efficient. Frequent leaching under drip irrigation has several advantages: the additional water maintains salinity below the harmful level; the volume of soil low in salt content will be larger following each irrigation; and the larger volume acts as a buffer to minimize the movement of salts at the edge of the wetted zone back to the roots. The amount of leaching required depends on the salt concentration of the irrigation water, the crop, and the frequency and uniformity of irrigation.

The distribution of salts within the soil profile differs markedly depending on the uniformity of water application and the differences in soil texture and root distribution. This is especially true under porous or multi-emitter drip systems where horizontal and vertical components of water movement tend to be nonuniform. A typical cross-section of such a profile, illustrated in Figure 3, shows both an isolated pocket of accumulated salts at the soil surface between horizontal lines, and a deep zone of salt accumulation whose location depends on the degree and efficiency of leaching. Directly beneath the emitters is a leached zone, with size dependent on the rate and frequency of irrigation and the volume of soil from which the crop roots extract water. This example also illustrates the effect leaching has on salt concentration and distribution in the root zone when the same quality of irrigation water (1350 mg/liter total dissolved salts,  $EC_w = 2.1$  mmhos) is used in both cases. The yield of crops moderately sensitive to salinity was doubled at 17 percent leaching compared with the yield at only 2 percent leaching.

The concentration of salts in a soil profile from widely-spaced emitters increases radially in all directions below the soil surface. As the rate of water



Fig. 4. Salt accumulation of the soil surface in a vineyard under drip irrigation using water with an  $EC = 1.2$  mmhos. The drip emitters were located approximately 30 cm from the vine. (San Joaquin Valley, UC-WSFS) 30 cm  $\approx$  1 foot.



application increases, the shape of the salinity distribution changes. Studies made by Bresler (1977), show that the salinity distribution in sand changes from elliptical, as shown in Figure 2, to more circular as the rate of water application increases. In fine-textured soils, and particularly in layered soils, considerably more water moves horizontally than vertically as the rate of application increases, resulting in relatively shallow depths of salt accumulation. For tree crops irrigated with several drip emitters per tree, the wetting patterns may overlap, thus reducing the level of salt accumulation between emitters under a tree.

Dissolved salts move with the water in the soil (fig. 3) and thus tend to accumulate at the perimeter of the wetted zone. Thus, because of the nature of the wetting pattern, salts become more concentrated in the zones lowest in soil-water, especially at the soil surface (see fig. 4). High salt concentrations at the soil surface can become an extreme hazard, especially following a rainfall (Bernstein, 1973). Under such conditions, unless the drip irrigation system is turned on, the rainfall will leach the surface salts downward into the root zone of the crop. If the drip irrigation system is turned on during periods of rainfall, the irrigation water originating from the emitter will tend to keep the salts away from plant roots. Soluble salts at or near the edge of the wetted zone can also become a hazard to crops. If the soil-water removed by transpiration is not frequently replenished, the soil-water content in the root zone is reduced below that at the edge of the wetted zone and soluble salts will tend to move toward the plant roots and decrease crop production.

Under drip irrigation, seasonal rains are needed to leach the soil of accumulated salt or additional irrigation water must be applied to leach the salt

below the root zone to prevent subsequent loss of crop production. Where rainfall is insufficient, leaching of surface-accumulated salts under drip irrigation has been successfully accomplished with portable sprinkler systems.

### Conclusions and applications

The wetted soil volume under drip irrigation is normally smaller than under other irrigation methods, thereby restricting plant root systems both horizontally and vertically. Both water and fertilizer management practices must therefore be modified to maintain adequate water and nutrient supply to the crop at all times (Rolston *et al.*, 1979).

Drip irrigation systems must be engineered to meet the crop water requirement while applying water at a rate no faster than the soil can accept it. Because the rate of infiltration of soils typically decreases with time, the longer the drip system is operated the greater the potential for ponding and subsequent run-off. In soils of very low infiltration rates, ponding can be avoided only by cycling the system at frequent intervals (pulse irrigation) within the irrigation time or by using devices (foggers) other than conventional emitters for localized irrigation (see Chapter 8). To maintain high levels of water content in the wetted zone and to avoid ponding and run-off, drip irrigation systems should be operated as frequently as possible. Frequent irrigation may be accomplished easily without increased labor costs through automation.

When drip irrigation is used properly, soil water content remains high, aeration is adequate, and the salt content of the wetted zone is relatively low. This enhances root proliferation and subsequent crop growth.



Salt accumulation under drip irrigation. Note salt build-up at fringes of wetted zone.

# Chapter 3

## Crop Responses to Drip Irrigation

### Crop response to soil water regime

The principal special features of drip irrigation from the standpoint of crop response are (1) the potential for maintaining relatively constant, high soil water content by very frequent applications of water, and (2) the wetting of only a portion of the total volume of soil, often involving only part of the crop's active root zone.

Under most climatic conditions, even well-watered plants experience mild water deficits during the day, yet they grow and produce at maximum levels. Numerous experiments have shown that there is clearly a soil water level above which daily plant water deficits remain unchanged and crops grow and produce equally well. Well-managed drip irrigation systems should be capable of maintaining a soil water level well above the threshold below which crop growth and yields are reduced. Whereas determining the threshold level is important for scheduling under most other methods, it is not necessary with drip irrigation, where keeping the soil water well above that level is a feasible management practice. On the other hand, very high levels of soil water should be avoided; saturated, or nearly-saturated, soils can cause injury from inadequate aeration or by root rot caused by fungi.

The threshold soil water level varies with soil properties, evaporative demand, and crop growth stage. In soils that have very low water storage capacities, water levels under conventional surface irrigation techniques or portable sprinkler systems often fall below the threshold value between irrigations. It is under such conditions that the frequent applications of water through the drip system give that method a definite advantage. In very coarse textured soils, increased yields for several truck crops have been reported under high-frequency drip irrigation over yields obtained under conventional sprinkler and furrow irrigation (Goldberg and Shmueli, 1970).

In soils that allow extensive root development and proliferation, have moderate to high water storage capacities, or both, adequate soil water levels needed for maximum production may be attained under a variety of irrigation methods and frequencies. Any such method then, including drip, would have the same production potential under optimum management. Bernstein and Francois (1973) reported no differences in yield of

peppers irrigated by drip, sprinkler, and furrow provided that good management practices were followed with each method. In experiments on deep sandy soil in Arizona, U.S. Salinity Laboratory Staff (1977) found no differences in trunk growth and yield between oranges irrigated daily by drip and bi-weekly surface irrigation.

When irrigation water contains excessive amounts of salts, high-frequency drip irrigation minimizes the detrimental effects of the salinity by maintaining high soil-water levels, thus preventing further salt concentration as water is removed by the crop. Bernstein and Francois (1973) reported that when brackish water was used, yields of pepper irrigated by drip were higher than those obtained under sprinkler or furrow irrigation.

### Yield responses to water deficits under drip irrigation

With few exceptions, water deficit or stress reduces crop yields if it is sufficiently severe to reduce water use through transpiration. Therefore the crop should always be supplied with the quantity of water it can utilize under prevailing climatic and ground cover conditions. That quantity is known as the crop evapotranspiration (ET) requirement (see Chapter 4). Additional water added above the ET requirements is lost as deep percolation below the root zone.

If water is applied frequently (e.g., daily) on the surface at the rate that is being removed by the ET process, a steady moisture condition develops with the upper soil being the wettest and the water content decreasing because of absorption by roots to a depth at which soil water content is unaffected by irrigation. If such a regime is begun before much water has been depleted from the root zone soil, all the soil is quite moist to a considerable depth. If the entire soil surface has been previously wetted by rainfall or by nonlocalized irrigation, water persists for a considerable period in the soil below that dried by evaporation (below 6 to 12 inches). Such water may then act as a buffer should the drip system fail to operate properly. More commonly, such generalized wetting does not occur or localized irrigation is not started until most soil water is depleted. All except the locally wetted soil is dry and the irrigated soil becomes shallow as well as restricted laterally.

Water deficits will develop under drip irrigation when the combination of the volume of water applied through the drip system and the stored soil water are insufficient to meet the crop ET demand. Under such conditions, yields are reduced below those that could be obtained under adequate water supply. The table illustrates the reduction in yield of processing tomatoes at Davis as the ET decreases below its maximum rate.

Effect of Deficit Drip Irrigation on Tomato Yield

Water applied (in)	ET (in)	Fruit yield (tons/acre)		Relative ET (%)	Relative ripe fruit yield (%)
		Total	Ripe		
26.9	25.0	82.3	59.5	100	100
21.7	22.6	64.2	50.3	90	85
16.1	17.7	48.0	38.2	71	64

### Patterns of root development under drip irrigation

The localized wetting of drip irrigation is an advantage in germinating seeds or watering young plants whose root systems have not yet explored all the soil between rows for periods ranging from a few weeks (for annual plants in row spacings of 2 to 5 feet) to several years (for orchards in 20- to 30-foot rows). Fully grown plants, however, explore the soil between rows thoroughly, and it is not unusual to find water extraction as rapid midway between rows as in the row itself.

The question then becomes: What portion of the root zone must be wetted to adequately supply the crop and eliminate yield-reducing levels of plant water stress? There is no definitive answer, partly because little research has been conducted. Plant roots tend to proliferate in the moist zone, so plants do adapt to an appreciable extent. Greatest care is needed during the period when an orchard or vineyard with large vines or trees is converted from conventional irrigation methods to one that employs a highly localized wetting pattern. If at all possible, the conversion to drip irrigation should be made during periods of low evaporative demand.

Theoretically, there is an interaction between the level of soil water maintained and the degree of localization, with greater localization requiring higher general soil water content to avoid water stress. Excessively localized wetting is most harmful during especially hot, dry, windy periods when evaporative demand is very high.

Experience has shown that mature orchards with as little as 20 percent of the lateral extent of the root zone wetted maintain good vigor and produce well, provided that enough water is applied so that the ET demand of the orchard is fully met. The question remains whether such orchards

would produce any better with less localized irrigation. Nutrient deficiencies by excessively localized irrigation may be an additional complication even when the water supply is adequate. In certain soils of the Sacramento Valley, potassium deficiency occurs in prunes under drip irrigation. The deficiency can be easily corrected by injecting potassium fertilizers into the drip system (Uriu *et al.*, 1979).

Root systems of drip-irrigated trees are often considered to be confined to the zone wetted by the irrigation system, but perennial plants in areas of appreciable rainfall develop roots through all the soil of the normal root zone. Once the soil outside the irrigated zone is fully depleted of available water, the root system is essentially dormant in the dry soil but is present and ready to resume activity when the soil is rewetted. Thus only in rainless areas is the root system confined to the irrigated zone, and even there confinement probably is not complete. Because of greater proliferation in the irrigated zone, rooting is more dense there, and water extraction capability is greater.



Proliferation of roots in the moist soil under emitter in mature peach orchard.

# Chapter 4

## Evapotranspiration and Drip Irrigation Scheduling

Water is applied in drip irrigation to satisfy the *crop water requirements*. Water losses from a cropped area to the atmosphere result from evaporation from the soil (E) and from plant surfaces (transpiration, or T). The combination is called evapotranspiration (ET) and is equivalent to the crop water requirements. Additional applied water may move beyond the reach of the crop roots as

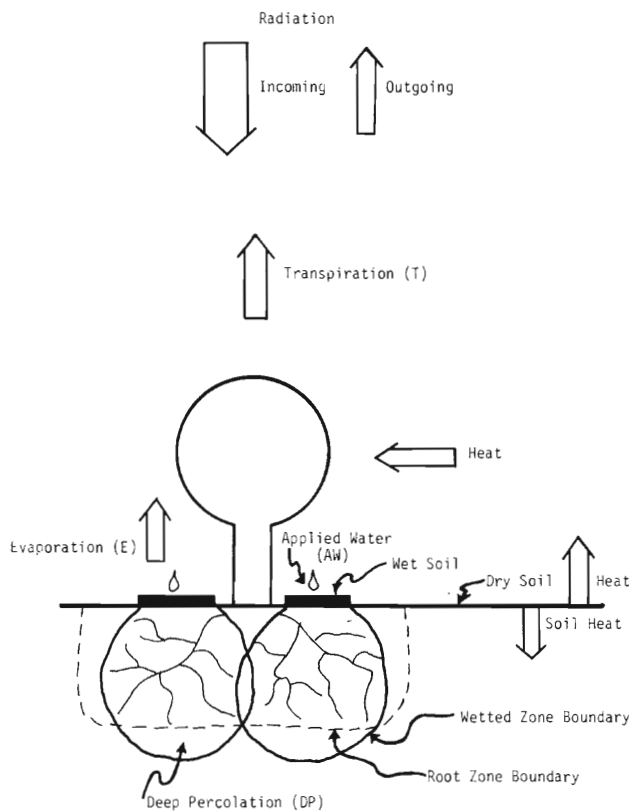

Fig. 1. Radiation and water balances of a plant under localized irrigation.

deep percolation losses (fig. 1) and may be considered part of the irrigation water requirements.

Under drip irrigation, the water applied (AW) is then either used in the ET process, lost as deep percolation, or may change the soil water content in the root zone (fig. 1). However, if the soil water content is kept fairly constant under high-frequency irrigation and deep percolation losses are minimized by monitoring the soil water status at the bottom of the root zone, the applied water could be equal to the evapotranspiration. Thus, knowledge of ET is essential for appropriate irrigation scheduling under drip irrigation.

It should be pointed out that, under conditions of high soil or water salinity, leaching requirements (see Chapter 2) should be added to *irrigation water requirements*. This is a common practice in drip irrigation of salt-sensitive crops (see Chapter 9).

### Evapotranspiration under drip irrigation

Evaporation of water requires heat energy. The amount of irrigation water that can be used in the ET process is limited by the availability of energy which in turn depends on the local climate. Solar radiation is the primary source of energy in the ET process but other energy sources must be considered too.

The most significant crop factor affecting ET is the amount of ground area covered by the crop. Evaporation from the soil surface is high following an irrigation, but decreases drastically as the soil surface dries after the initial wetting. Therefore the ET in situations where the crop covers only a fraction of the ground is well below the potential or maximum ET at full cover unless frequent irrigation or precipitation is involved. (This fact is illustrated in Figure 2, which shows the daily ET losses from a sprinkler-irrigated bean crop compared with the daily ET by a full-cover grass surface.)



Tensiometers and neutron probe access tubes in place to monitor soil water levels.

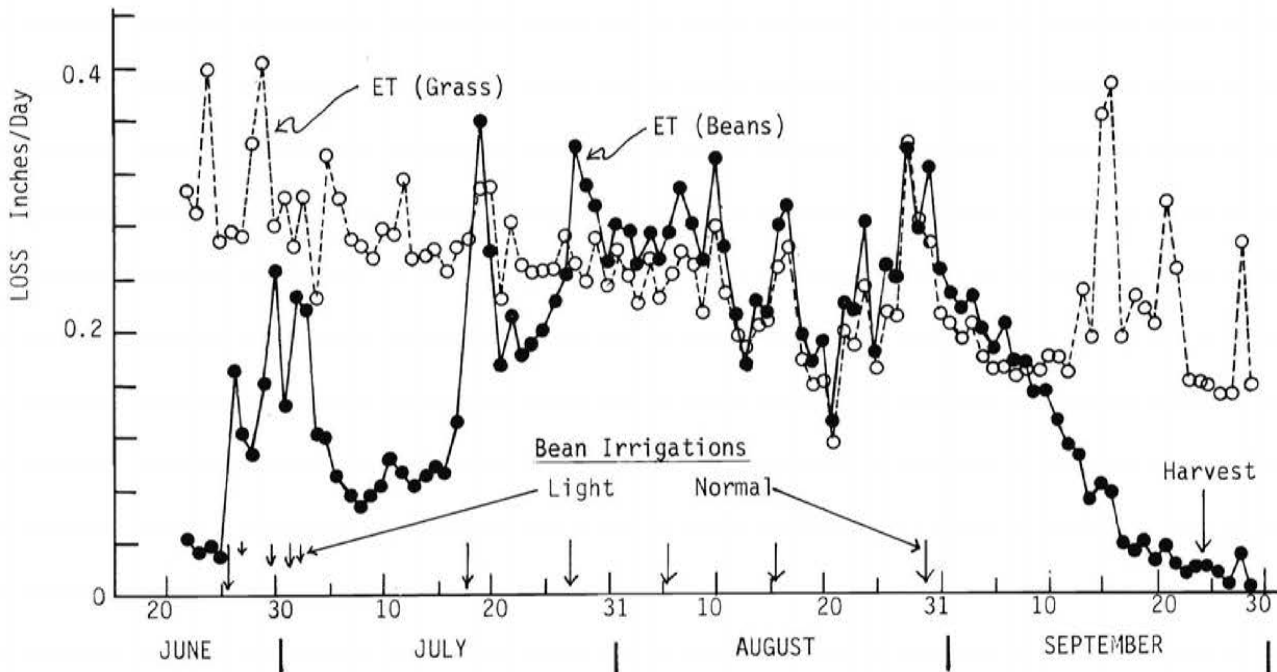
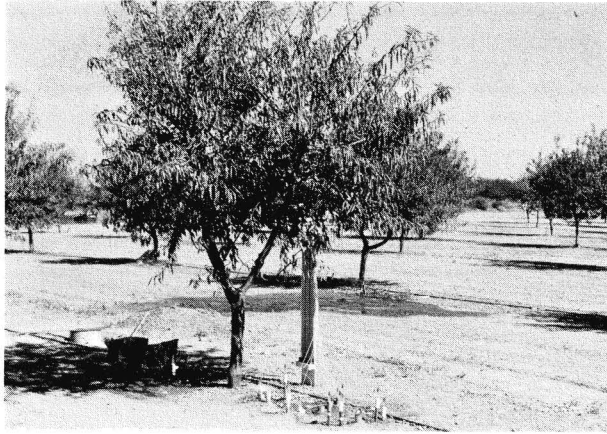

Fig. 2. Daily ET data for beans and grass measured using 2 lysimeters 20 feet in diameter. Davis, California, 1968. Unpublished data from W.O. Pruitt.



Young almond tree under drip irrigation instrumented to obtain estimate of ET.

Many studies have been conducted in California to predict the ET requirements of various crops under conventional irrigation methods (Pruitt *et al.*, 1972). However, because drip irrigation reduces wetted soil surface area, such predictions are not directly applicable to drip-irrigated crops. The following analysis of the peculiarities of the radiation and energy balances of a drip-irrigated plant emphasizes the difficulties in evaluating ET under drip irrigation.

Figure 1 shows a simplified radiation balance over an isolated plant. Part of the incoming radiation is reflected or re-radiated back to the atmosphere as outgoing radiation. The balance between the two is called net radiation ( $R_n$ ).  $R_n$  of the plant surfaces is mostly used in transpiration ( $T$ ) while the portion of  $R_n$  at the soil surface wetted by the emitters is dissipated as soil evaporation ( $E$ ). However, as only a small fraction of the ground surface is wetted by the emitters, soil  $E$  under drip irrigation will be substantially less than under methods that wet the entire soil surface during times when a large percentage of the soil surface remains unshaded by the crop.

At the dry soil surface areas,  $R_n$  is dissipated mainly by heating the soil and the air around it; some is also re-radiated toward the wet zones. The hot air may also be transferred by convection into the wet zones. Both effects tend to increase ET from the wet zones above that which would occur if the surrounding areas were also wetter. Thus, in closely-spaced row crops, during periods of incomplete cover, the evaporation losses under drip irrigation may even exceed those of fields irrigated infrequently by furrow or sprinkler methods.

In attempting to utilize ET information developed under conventional irrigation methods for drip irrigation scheduling, two differences must be evaluated. First, soil  $E$  may be diminished under drip irrigation where the major share of the soil

surface is always dry with a small portion always moist. Second, and probably of less magnitude, transpiration increases under drip irrigation relative to the transpiration under methods that generally wet all the soil surface but at infrequent intervals. Several experimental evaluations of the ET reduction under drip relative to other irrigation methods have been conducted. The results varied depending on the degree of plant cover and the frequency of irrigation under the conventional techniques used.

The following are three circumstances under which the reduction in  $E$  under drip irrigation has varying effects. The most favorable is that of tree crops in the early growth stages which have no need for water to be applied in soil areas where roots have not yet explored. Since young trees only shade a small fraction of the orchard, localized irrigation will use only a fraction of the water needed in methods where most of the ground surface is wetted by irrigation. As trees grow, however, they will cover a greater portion of the orchard and the savings due to  $E$  reduction should decrease. (Chapter 9 gives data on applied water under drip- and sprinkler-irrigated avocado trees from one to five years old that illustrate this point.) A second situation is hedge row plantings of trees or widely-spread row crops in the early growth stages. Here, although the advantage of drip irrigation is presumably reduced as the percent ground cover of the crop increases, significant reductions in ET (perhaps 10 to 25 percent) may be possible, particularly in situations where frequent applications are required under conventional irrigation methods. In a third situation, the irrigation of row crops, vineyards, or orchards with nearly full shading of the ground, the water savings advantage noted above for drip irrigation may become insignificant. Recent data (Pruitt, Fereres, Henderson, and Hagan, unpublished) show that the ET rates of drip- and furrow-irrigated tomatoes at Davis were nearly identical after the crop had reached 50 percent ground cover. Apparently, most of the water used by crops near full cover is through transpiration, with soil evaporation only a small fraction of the total ET use. It is also possible that in the latter cases, the reduction in  $E$  through drip may be offset by an increase in  $T$  as discussed above.

Significant research efforts are now being directed at quantifying the ET under drip irrigation. However, much more research is needed to assess the water savings potential of localized irrigation due to reductions in  $E$  under the wide range of crops, soils, and climates of California.

### Scheduling irrigations

There are many methods of irrigation that, because of labor costs or technical constraints, are best used when irrigating as infrequently as possible. How-

ever, drip and other permanent systems can apply any desired amount of water without an increase in labor costs or excessive waste. Irrigation scheduling techniques based on a water budget and on using the soil as a water reservoir between irrigations are not as applicable to drip irrigation as to other methods. Under drip, the irrigator needs to be concerned *only* with the ET and should try to replenish past ET losses frequently (daily to weekly depending on soil type and evaporative demand—see Chapters 2 and 3). Long intervals between drip irrigations, or failure to meet the crop ET demand—or both—are probably more risky under this method because of localized wetting patterns and should be avoided. Particularly in marginal soils with very little soil water storage capacity, crop water stress develops extremely fast under drip irrigation when the irrigator fails to meet the ET demand.

Data on normal ET demand of mature deciduous orchards, citrus orchards, and vineyards (see figs. 3 through 7) represent the long-term average consumptive use of crops that have reached at least 70 percent ground cover. It should be noted that ET rates 10 to 25 percent above average may occur in certain years, particularly during spring and fall in California's Central Valley.

**Example** (converting ET data to gallons per tree per day): Figure 3 shows that the ET in July for clean cultivated deciduous orchards in the Sacramento Valley is 7.6 inches or 0.25 inches per day (7.6 divided by 31). If the tree spacing is 24 feet by 24 feet, the actual ET in gallons/tree/day (GTD) is:

$$\text{GTD} = 0.25 \text{ in/day} \times 24 \text{ ft} \times 24 \text{ ft} \times 0.623 \text{ g/in/ft}^2 = 90.0 \text{ gal/tree/day}$$

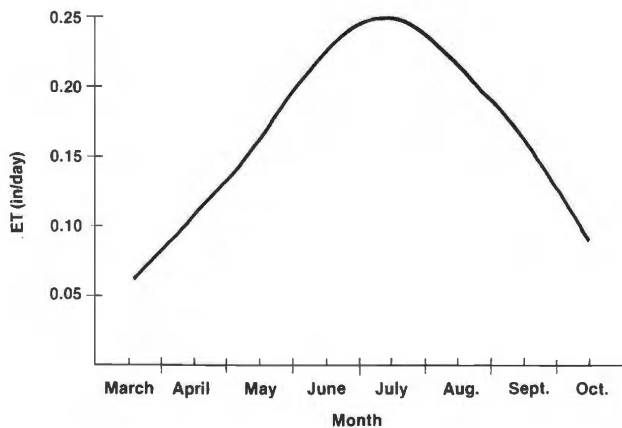
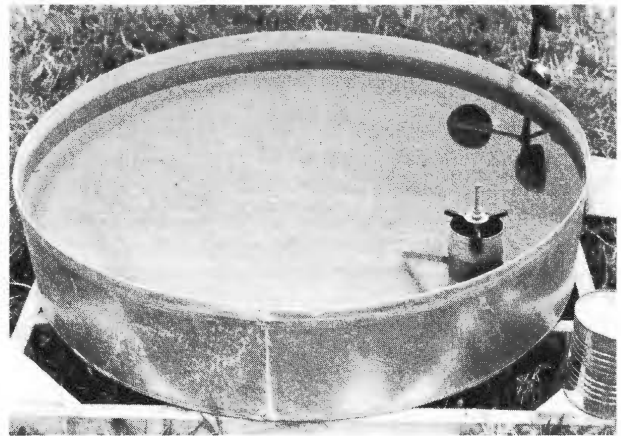

Fig. 3. Seasonal ET rates in a clean-cultivated deciduous orchard, Sacramento Valley.



Class A evaporation pan frequently used in drip-irrigation scheduling.

For young trees that have not reached full cover there are potential savings in ET under drip irrigation compared with other methods. Currently, several research projects are being carried out in the Central Valley to develop ET information for young drip-irrigated trees. A summary of the information collected so far is presented in Figure 8, which shows the approximate relationship between the ET of young deciduous orchards (almond and peach) and the percent of area shaded by the tree canopy measured around noon, in late June to early July. While we recognize that percent shade by canopy may not be the most appropriate factor to use to estimate the ground cover in orchards because of differences in tree configuration (compare walnuts with almonds, for example), it is the simplest means of evaluating tree canopies. Information is now being collected to relate ET to tree size and shape.

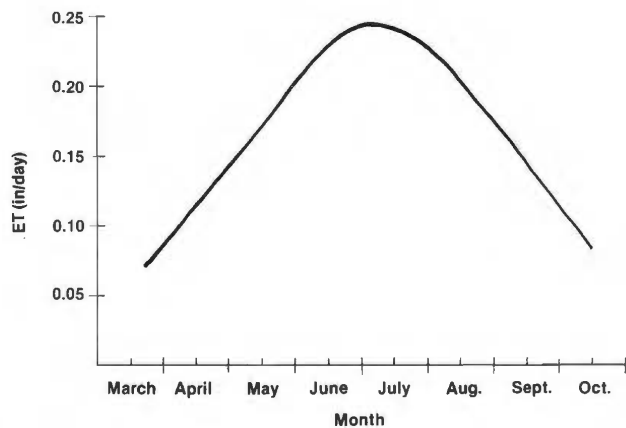

Fig. 4. Seasonal ET rates in a clean-cultivated deciduous orchard, San Joaquin Valley.

Note that the empirical relationship between percent ET and percent shaded area by young trees departs markedly from the 1 to 1 line, indicating that young trees will use more water than could be inferred by measuring the interception of direct radiation as was discussed in the ET section of this chapter. The relationship in Figure 8 applies to orchards where the soil is kept bare and dry throughout the season and where temperatures during the summer are hot, as in the Central Valley. Also, the relationship (fig. 8) may be modified as more research data become available.

The data in Figure 8 can be used to convert either the normal or current ET rates for mature orchards to the water requirements of young deciduous orchards. Tables 1 and 2 show the normal water requirements of young orchards as they grow.

*Example:* Assume that a given orchard planted 15 feet by 20 feet has 20 percent shade, and the current ET rate (of mature orchards) given by the

newspaper is 0.31 in/day. From Figure 8, 20 percent shade approximately equals 50 percent ET. Thus:

$$\begin{aligned} \text{gallons/tree/day} &= 0.31 \text{ in/day} \times 0.5 \text{ (ET)} \times 15 \text{ ft} \times \\ &\quad 20 \text{ ft} \times 0.623 \text{ g/in/ft}^2 \\ &= 29 \text{ gallons/tree/day} \end{aligned}$$

Figures 3 to 7 give ET information for normal or average conditions. However, ET varies from year to year particularly in the spring and fall. Current ET values are available in many locations in California through newspapers, radio stations, and so on. For greater accuracy in irrigation scheduling current ET figures should be used.

### Scheduling irrigation using soil water measurements

Growers should monitor soil water conditions around emitters frequently in the early stages of the use of a drip system. The monitoring may be done

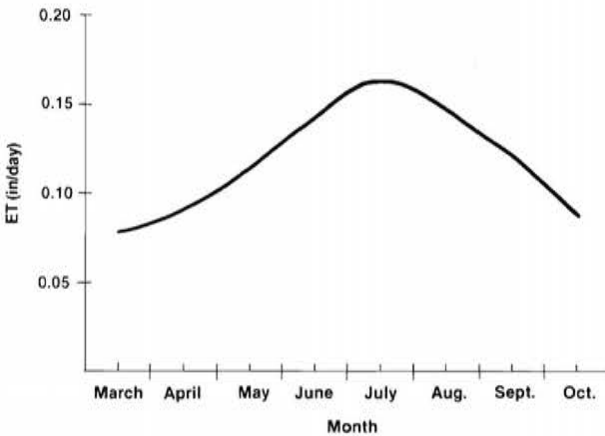

Fig. 5. Seasonal ET rates in clean-cultivated deciduous orchards, south coast-coastal valleys.

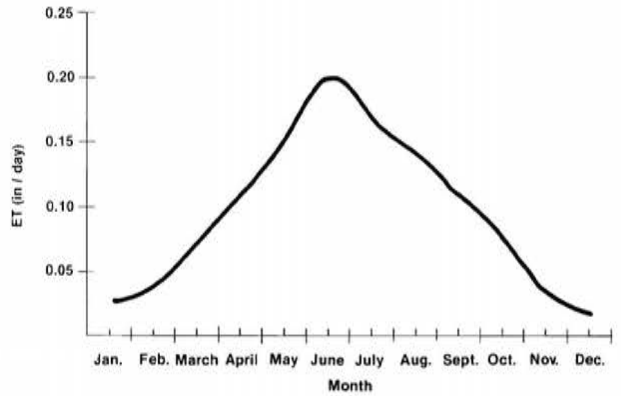

Fig. 6. Seasonal ET rates in a citrus orchard, San Joaquin Valley.

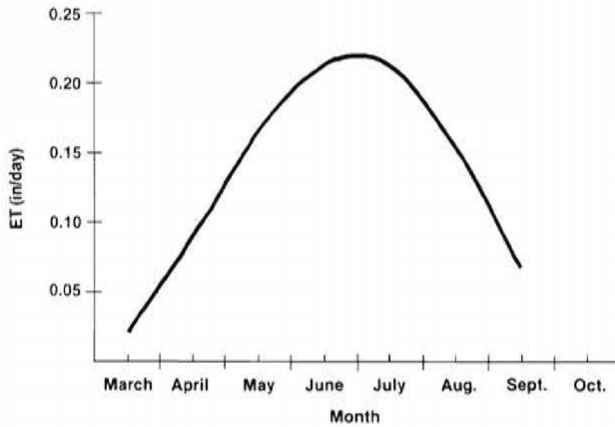

Fig. 7. Seasonal ET rates in a grape vineyard, San Joaquin Valley.

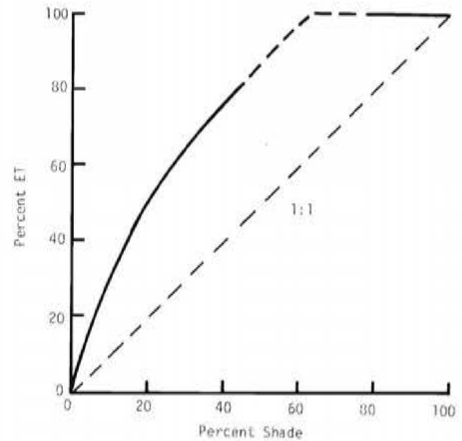

Fig. 8. Relationship between percent ground area shaded by tree canopy in midsummer and ET of drip irrigated young trees as a percent of ET of mature orchards. NOTE: Dashed portion of upper line indicates portions of the relationship where no experimental data are yet available.



by probing the soil with a soil probe or an auger to check the lateral and vertical penetration of water.

Because the soil water content in the vicinity of the emitter is generally quite high, tensiometers may be used for monitoring soil water conditions in the wetted zone. The following recommendations, based on experimental evidence, suggest a method for using tensiometers to schedule irrigations with drip systems.

Two tensiometers should be placed in each observation point, and should be installed a few inches away from the emitter. (An exception should be made when frequent ponding occurs in heavy-textured soils; in that case they should be 1 foot to 18 inches from the emitter.) One tensiometer should be at the 12- to 18-inch depth, which is generally the part of the root zone that dries out first. Under good management that tensiometer will read between 10 and 30 centibars, except on days of unusually high evaporative demand, when it will read higher. Another tensiometer should be placed deeper, from 3 to 5 feet depending on soil depth and extent of the root zone. The readings from that tensiometer, corrected for depth, give a good indication as to whether the amount of water being applied is sufficient to meet ET. If readings increase with time, the volume of water applied

should be increased. If readings are low (corrected reading, 5 to 15 centibars) the volume applied should be reduced. If more accurate information is desired, two deep tensiometers, 6 inches apart (for instance, 42 and 48 inches), should be installed and will provide information on whether soil water is flowing upward toward the root zone or downward, being lost to deep percolation.

Because soil water conditions are apt to vary in a field, several soil monitoring stations will provide a more accurate documentation of soil water conditions than just one.

### Conclusion

Permanent, localized irrigation systems can meet crop ET requirements with minimum losses, thus achieving high irrigation efficiency. Such systems, however, require precise irrigation scheduling, which may best be done by combining reliable ET information with soil monitoring. Excessive percolation losses, insufficient water applied, and poor distribution uniformity due to clogging result in lowering the efficiency of water use. The full potential of a well-designed drip system can only be realized under appropriate water management practices.

TABLE 1.  
Water Use in Clean-Cultivated Deciduous Orchards\*, Sacramento Valley

Month	Maximum percent shade in mid-summer									
	5	10	15	20	25	30	40	50	60	70-100
	gal/tree/day									
March	3.7	7.5	10.9	13.1	15.2	17.0	20.2	23.2	26.1	26.6
April	5.4	10.7	15.7	18.1	21.8	24.5	29.1	33.3	37.5	38.3
May	7.9	15.9	23.3	27.8	32.3	36.3	43.1	49.4	55.6	56.7
June	11.2	22.4	32.9	39.3	45.7	51.3	60.9	69.7	78.5	80.1
July	12.3	24.4	36.1	43.1	50.2	56.3	66.9	76.5	86.2	88.0
Aug.	10.4	20.7	30.4	36.3	42.2	47.4	56.3	64.5	72.6	74.1
Sept.	8.0	16.1	23.5	28.1	32.7	36.8	41.9	50.0	56.3	57.4
Oct.	4.4	8.8	12.8	15.3	17.8	20.0	23.8	27.2	30.6	31.3

\*Tree spacing: 24' x 24'

TABLE 2.  
Water Use in Clean-Cultivated Deciduous Orchards\*, San Joaquin Valley

Month	Maximum percent shade in mid-summer									
	5	10	15	20	25	30	40	50	60	70-100
	gal/tree/day									
March	2.1	4.2	6.2	7.4	8.6	9.7	11.5	13.1	14.8	15.1
April	2.9	5.8	8.4	10.1	11.7	13.2	15.6	17.9	20.2	20.6
May	4.6	9.3	13.6	16.3	18.9	21.2	25.2	28.9	32.5	33.2
June	6.0	12.0	17.6	21.1	24.5	27.5	32.7	37.4	42.1	43.0
July	6.3	12.7	18.5	22.2	25.8	28.9	34.4	39.3	44.3	45.2
Aug.	5.4	10.8	15.8	18.9	22.0	24.7	29.3	33.6	37.8	38.6
Sept.	3.8	7.7	11.2	13.4	15.6	17.5	20.8	23.9	26.9	27.4
Oct.	2.2	4.4	6.4	7.7	8.9	10.0	11.9	13.6	15.4	15.7

\*Tree spacing: 20' x 15'

# Chapter 5

## Application of Chemicals through Drip Systems

Drip irrigation introduces possibilities for precision application of fertilizers and other chemicals. Roots develop extensively in the more limited volumes of soil wetted by drip systems, allowing for efficient placement of plant nutrients and pesticides that can be moved into the root zone with the water. At the same time, the restricted root growth necessitates that type of fertilizer application to prevent nutrient deficiencies due to the limited soil volumes explored by roots. The principles of nutrient movement and application under drip irrigation have been summarized recently (Rolston *et al.*, 1979).

Many drip irrigated orchards are planted on such steep terrain that the most practical method of applying chemicals to the soil is through the irrigation system. Even when terrain is flatter, injection of chemicals through the drip system offers important labor saving advantages over ground application. The money saved in mechanized chemical distribution helps justify the high initial capital investment of drip systems.

### Application of fertilizers

The element most often applied through drip systems in California is nitrogen. However, drip application of phosphorus and potassium is not uncommon for vegetable crops that have high fertilization requirements. There is limited experi-

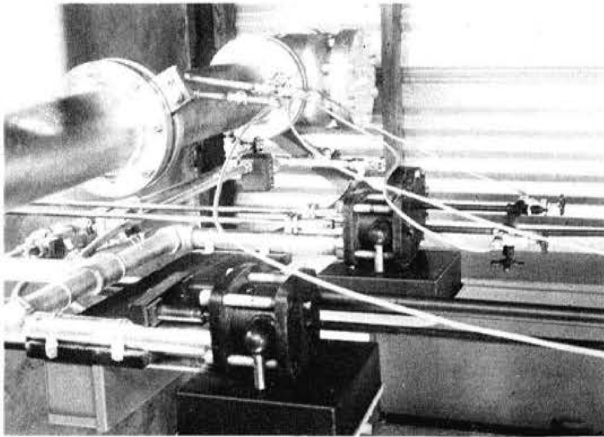

Fertilizer injecting pumps and accessories.

ence but increasing interest in applying phosphorus and potassium, and zinc as well, to tree crops by drip irrigation where leaf analysis indicates the need.

To avoid clogging, chemicals applied through drip systems must meet certain requirements. The chemicals must be highly soluble. If more than one material is used in preparing concentrated stock solution for subsequent injection, the chemicals must not react with each other to form a precipitate. And the chemicals must be compatible with the elements they will come into contact with after injection into the irrigation water.

The particles of some solid fertilizers that meet the above requirements are coated with clay or wax to prevent caking in storage. The coatings can cause scum to form on the surface or sludge to deposit on the bottom of stock solutions. Several precautionary measures can prevent such residues from reaching the emitters: locating the discharge tube a few inches above the bottom of the stock solution tank, and periodic removal of any scum or sludge. Wetting agents can be helpful in emulsifying wax coatings and preventing scum formation. Locating the injection point before the filter in the control head also minimizes emitter clogging.

Concentrated fertilizer solutions or those with very low or high pH may corrode copper, zinc, and bronze alloys, and other metal parts of irrigation systems. Therefore, the components of the system that come in contact with corrosive solutions should consist of stainless steel, plastic, or other noncorrodable materials.

When it is necessary to apply chemicals that can clog the drip system, those materials may be placed on or mixed with the soil under the emitter, allowing the irrigation water to displace them into the root zone.

### Injectors and uniformity of distribution

Two types of injectors can be used. One is the power injector. The injection pump is powered by an external source—either electricity, gasoline, or a water power source coming from the pressure of water in the irrigation system. With power injectors, injection can be regulated more precisely and materials can be injected at constant concen-

tration until the required amount has been applied. Another form of injector, the differential pressure type, has its inlet and outlet pipes connected to the main line at two points having different water pressures (fig. 1). This causes the water to flow through the injector, gradually displacing the fertilizer it contains. Thus, the concentration of the chemical applied changes continuously, being gradually diluted until it has all been discharged into the irrigation system.

Pressure differential (PD) injectors, such as the one shown in Figure 1, can provide adequate service when their advantages and limitations are understood. The PD injectors are simple and do not require additional electrical or gasoline operated pumps for injection. They are frequently the only means of applying chemicals when no source of power is available. The chief disadvantage is that uniform distribution may be difficult to achieve.

A knowledge of the dilution rate allows one to adequately judge when the fertilizer container can be drained and recharged without excessive chemical loss, or contamination of the surrounding soil, which may result in crop injury.

Because there are many shapes, sizes, and designs of injector tanks, complete immediate uniform mixing may not result in all units. However, the curves in Figure 2 are based on calculated values and necessarily assume immediate uniform mixing. Mixing of inflow water will also depend upon the characteristic of the material in the tank, such as its chemical nature, temperature, concentration, specific gravity, rate of flow, solubility, and so on.

Flow may be determined by use of flow meters, flow control valves or orifices. Tubing of variable length and diameters can be used as an outflow line or as a restriction in the outflow line when the differential pressure is known or can be determined from gauges. When very low delivery rates are required, microtubing may be used to decrease the flow rates from the injector.

Table 1 gives flow rates for various pressures and lengths of 0.035-inch-inside-diameter microtubing. Placing a clamp or a valve at point A on

the outflow line in Figure 1 and then bridging past the clamp is one way to achieve a low flow rate. A filter should precede the microtubing. Since the diameter of the microtubing is considerably less than the diameter of the inflow and

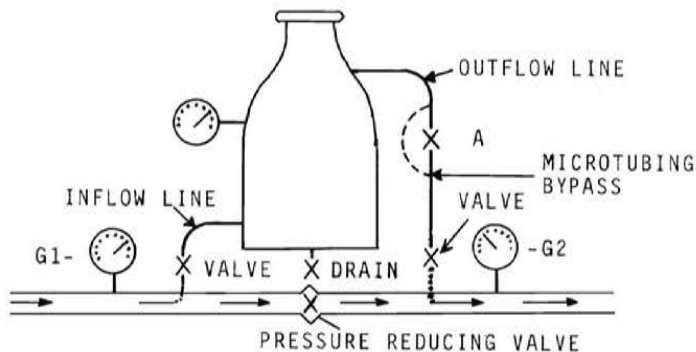

Fig. 1. Schematic diagram of a pressure differential applicator.

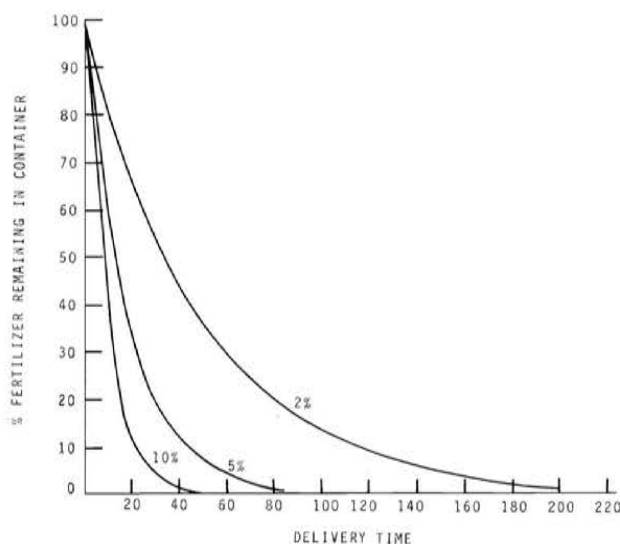

Fig. 2. Calculated fertilizer application curves for different flow rates.\*

\*Time is read directly in minutes or hours without conversion.

TABLE 1.  
Flow Rate as Influenced by Length of Tubing and Pressure Differences  
for 0.035-Inch-Inside-Diameter Tubing

Length of tubing (inches)	Pressure drop (pounds per square inch)								
	1	4	8	10	gallons per hour				
					12	16	20	25	30
3	.88	2.4	3.9	4.6	5.2	6.4	7.5	7.9	
6	.54	1.5	2.4	2.8	3.2	3.9	4.6	5.4	6.1
9	.40	1.1	1.8	2.1	2.4	2.9	3.4	4.0	4.6
12	.33	.88	1.5	1.7	1.9	2.4	2.7	3.3	3.7
18	.25	.66	1.1	1.3	1.5	1.8	2.1	2.5	2.8
24	.20	.54	.88	1.0	1.2	1.5	1.7	2.0	2.3
30	.17	.46	.75	.88	1.0	1.2	1.5	1.7	1.9
36	.15	.40	.66	.78	.88	1.1	1.3	1.5	1.7

outflow lines, the desired flow rates can be achieved by varying the length of microtubing. Tube lengths can be combined to give the desired flow rates for the pressure drop determined by the difference between gauge 2 and gauge 1.

If larger flow rates are needed, Table 2 should be used. The data in Table 2 were determined under field conditions using gauges and meters to measure pressure drops and flow rates. The total length of the inflow and outflow lines and the pressure drop from gauge 1 to gauge 2 are used to estimate flow. Flow rates can be modified by varying the pressure drop or the total length of tubing. Other tables may have to be developed for lines of different diameters. For accurate rates, actual field tests may be required.

When using the curves in Figure 2, the flow in gallons per hour must be read in hours of delivery time; likewise, flow in gallons per minute must be read in minutes of delivery time.

Application is determined by calculating the percent of flow based on the capacity of the container. Flow rate curves are expressed as percent of the container volume. For example, if a 100-gallon container has a flow through of 5 gallons per hour, then use the 5 percent curve. If only one half the material is to be applied, then the unit should be turned off after 18 hours. The curve also indicates that it will take at least 100 hours to reduce the concentration to less than 1 percent. If the same 100-gallon container has a flow-through of 5 gallons per minute, then in 18 minutes one half of the material should have been applied.

## Nitrogen

Nitrogen fertilizer is available in both liquid and dry form. Increasingly, liquid fertilizers—generally containing nitrogen in combination with other plant nutrients—are being formulated especially for application through drip systems.

**Characteristics of different nitrogen sources.** Most dry nitrogen fertilizers have high solubilities

(as shown in Table 3) and thus are suitable for preparation of concentrated stock solutions for injection. All of the fertilizers listed in Table 3 are good sources of nitrogen. They contain nitrate or ammonium, or they contain nitrogen in a form that is converted quickly to ammonium in soils. The end product of all of these fertilizers, upon reaction in soils, is nitrate.

Theoretically it is possible to get equal results from the use of various nitrogen fertilizers, pound for pound, of nitrogen. However, some differences in chemical characteristics must be taken into account. For example, urea and nitrate will move immediately downward in soil with the water. Ammonium is held by soil particles and will not move as far in the soil profile as urea or nitrate under conventional methods of irrigation; however, under drip irrigation the nitrogen content under the emitter is usually high enough to saturate the soil's fixing sites and permit ammonium to move into the root zone. Ammonium will then be converted to nitrate by soil microorganisms and will move as do applied nitrates with subsequent irrigations (Rolston *et al.*, 1979). Furthermore, the acidity produced by different sources of nitrogen varies (as shown in Table 3, which gives the amount of calcium carbonate, or lime, required to neutralize the acidity produced

**TABLE 2.**  
Flow Rate as Influenced by Length of Tubing and Pressure Differences for 0.5-Inch-Inside-Diameter Tubing

Length of tubing (feet)	Pressure drop (pounds per square inch)		
	----- gallons per minute -----		
	2	5	10
10	2.8	5.2	7.4
15	2.5	4.7	6.6
20	2.2	4.3	6.0
25	2.1	3.8	5.4
30	1.9	3.6	5.0
35	1.7	3.3	4.6
40	1.5	3.0	4.3
45	1.4	2.8	4.1
50	1.3	2.7	3.9
75	1.0	2.0	3.1
100	.9	1.8	2.9

**TABLE 3.**  
Composition, Solubility, and Residual Acidity of Some Nitrogen Fertilizers

Material	% Nitrogen	Solubility (lb/gal)		Lbs calcium carbonate to neutralize acidity produced from 100 lbs N
		0°C	100°C	
Ammonium nitrate	33.5	9.84	72.62	185
Ammonium sulfate	20-21	5.92	8.59	550
Calcium nitrate	15.5	10.09	31.35	-100 (basic)
Urea	45	8.34*	(high)	158
Potassium nitrate	13	11.11	20.59	-115 (basic)
Ammonium phosphate	21	10.92†		357

\*17°

†15°C

by 100 pounds of nitrogen from different sources). Ammonium sulfate produces considerably more acid than other forms of nitrogen. Therefore it is less suitable for use in drip systems on soils that are naturally acid because of the possibility of lowering the pH of the soil solution excessively (pH below about 5.0 is excessive for most crops).

Nitrogen fertilizers with less acidifying power than ammonium sulfate may also acidify soils that do not contain lime. When fertilizer is distributed through drip irrigation systems, the material is applied in localized zones. As a result, the potential for acidification is somewhat greater than when the material is broadcast. A check on soil pH in the root zone from time to time is desirable when residually acid fertilizers (ammonium forms) are applied through drip systems on sandy soils that are already naturally acid. Such checks need not be done frequently: about once every two years should be adequate to detect any pH trend that might require changing fertilizer form to prevent excess acidification.

Anhydrous ammonia or aqua ammonia, if injected into irrigation water that contains appreciable amounts of calcium and magnesium, will cause those elements to precipitate because of an increase in water pH and may cause clogging. Other nitrogen fertilizers, including urea, are not likely to cause any adverse shift in the pH of irrigation water. Volatilization of nitrogen as  $NH_3$  can occur from anhydrous or aqua ammonia-injected water, another factor that makes the two fertilizer materials less suitable than others for use in drip systems.

**Clogging associated with nitrogen.** Although clogging problems are not commonly associated with nitrogen, microbial growth which can clog emitters is promoted by nitrogen solution remaining in irrigation lines between irrigations. The problem can be avoided by running the system at least one hour after applying the fertilizer to flush the lines. Some irrigation waters naturally contain considerable amounts of nitrate, making line flushing impractical. In such cases, use of

**TABLE 4.**  
Pounds of Nitrogen Fertilizer/Tree/Month  
to Supply Recommended Annual Rate\*  
of Nitrogen for Avocado Trees.

Tree age	Urea	Ammonium nitrate	Calcium nitrate
1	.028	.037	.081
2	.056	.075	.161
3	.092	.112	.242
4	.139	.187	.403
5	.278	.373	.806

\*8-month irrigation period

black plastic rather than white can help exclude light that is needed for some types of microbial growth. Injection of a biocide may be necessary for control where the problem is severe.

**Rates and timing of application.** It is believed by some that nitrogen fertilization efficiency is greater when applied by drip systems than when applied by other methods because precision placement confines the fertilizer to the root zone. While some refinement in recommended rates may result from future research, most growers now apply the conventionally recommended amount, split into increments. For example, a tree crop whose fertilization rate is 100 pounds of nitrogen per acre per year will receive in one month an amount equal to 100 pounds divided by the number of months irrigated. Using this method, a table (Table 4) was prepared for avocado growers. It lists the amount of nitrogen fertilizer a grower needs to apply per tree each month from three different fertilizers to meet the recommended yearly rate.

Table 4 is based on the assumption that nitrogen is applied monthly for an 8-month period. The total nitrogen applied during the 8-month period increases from 0.1 lb/tree (for 1-year-old trees) to 1 lb/tree (for trees 5 years old and older). To illustrate the use of Table 4, let us assume we have an orchard of 2,000 trees that are 3 years old and urea is the nitrogen source. According to the table, the monthly requirement per tree is 0.092 pound of urea which, when multiplied by 2,000, amounts to 184 pounds of urea required per month for the orchard. Amounts of ammonium nitrate and calcium nitrate that will supply an equal amount of nitrogen are also shown in the table. Such tables can be prepared for crops with different fertilization rates and different periods of irrigation.

Because growth rate varies with time, crop nitrogen demand will also vary. Some modification of the method discussed above would therefore seem desirable; however, there is insufficient information of this nature and more needs to be developed from trials conducted under field conditions.

Short-season crops that have relatively high fertilization rates, such as vegetable crops, require higher concentrations of nitrogen in the irrigation water than crops irrigated over longer periods and/or fertilized at lower rates. Research on commercial vegetable crops in San Diego County shows that the nitrogen concentration of irrigation water, resulting from fertilizer injection, may be as high as 2500 mg/l, apparently with no adverse effect. The total salt concentration of the irrigation water changed with the fertilizer injection

from 1 to 16 millimhos per centimeter. Guidelines on permissible concentration limits of fertilizer-injected waters are yet to be established.

### Phosphorus

Phosphate fertilizers injected into drip systems may react with calcium in irrigation water to form an insoluble precipitate that will clog emitters. However, field experiments have given a greater understanding of the use of phosphorus fertilizers, and have shown that proper management can prevent precipitation problems. To accomplish this the stock solution is acidified, either by mixing with sulfuric acid, or injecting sulfuric acid immediately after injection of phosphoric acid. Injection of the solution acidifies the irrigation water slightly and prevents precipitation of the phosphorus without causing any adverse effects in the soil. A number of liquid fertilizers containing phosphorus and formulated specifically for drip irrigation are available. In most cases growers who need to apply phosphorus through drip systems are advised to use the specially prepared fertilizers rather than attempt to formulate their own. The user is cautioned to maintain a low pH in the irrigation stream to avoid precipitation problems.

Movement of phosphorus in soils is so limited that its application to soil surfaces through irrigation systems has not been recommended. Recent research shows, however, that drip irrigation is an exception. Phosphorus has been found to have considerable mobility in soil when applied through drip systems at low rates (Rauschkolb *et al.*, 1976). For example, phosphorus, applied through a drip system as orthophosphate at a rate of 35 pounds per acre, moved 12 inches vertically and 10 inches horizontally in a Panoche clay loam—a five- to tenfold increase in phosphorus movement. The increase is due to the phosphorus being applied over a very small surface area (see fig. 3), which results in saturation of the soil's phosphorus fixing sites near the emitter and subsequent movement of phosphorus with the soil water.

The above information suggests that rates of phosphorus fertilization need not be high when applied through drip systems, although further trials are needed to establish recommended rates for various crops and soils.

No benefit is likely to occur from applying phosphorus repeatedly during the cropping season as is necessary for nitrogen. Plants generally need phosphorus early, so it is important that the element, if deficient in the soil, be applied before planting, at planting, or very shortly after planting. Should phosphorus deficiency symptoms develop during the growing period, however, drip irrigation systems offer the possibility of making late stage corrections.

### Potassium

The potassium requirements of most crops grown in California are met by the long-lasting reserves of available potassium in most soils. Notable exceptions are some vegetable crops, strawberries, and prunes, which at some locations need potassium fertilization to correct deficiencies or to maintain postharvest firmness.

Any of the common sources of potassium, i.e., the chloride, sulfate, or nitrate forms, may be used in drip systems. Clogging has not been a problem with their use. Their solubilities vary, as shown in Table 5. Heating the stock solution may be necessary to completely dissolve potassium sulfate. That form, and potassium nitrate, are preferred over potassium chloride for use on crops that are chloride sensitive. This includes most fruit crops and strawberries, but not vegetables.

Potassium, like phosphorus, generally moves to a very limited extent in soils. The applied potassium is adsorbed on the exchange complex of the soil. Research with prunes, however, dem-

TABLE 5.  
Composition and Solubility of Some Potassium Fertilizers

Material	%K <sub>2</sub> O	Solubility (lbs/gal)	
		0°C	100°C
Potassium chloride	62	2.89*	4.73
Potassium nitrate	44	1.11	20.59
Potassium sulfate	53	2.63*	2.01
		1.00†	

\*20°C  
†25°C

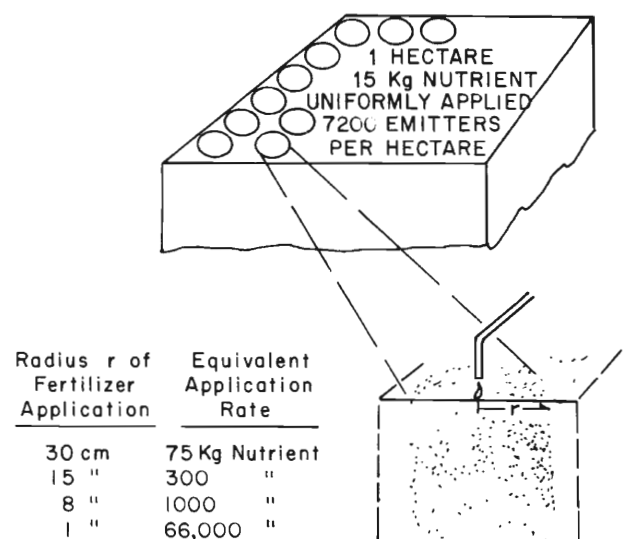

Fig. 3. Radii of fertilizer application and equivalent application rate for nutrient application through a trickle system.

onstrated that potassium could move 24 to 36 inches into the soil in one season when applied to small soil areas as with a drip system (Uriu *et al.*, 1977). Leaf potassium levels began increasing in less than one month after treatment was begun. A solution of potassium sulfate was injected to give a continuous potassium concentration of about 190 ppm in the irrigation water. The total potassium applied thus during the irrigation season was equivalent to about 10 pounds of potassium sulfate per tree—a conventional fertilization rate for correction of potassium deficiency in prunes. Possibly a lower rate applied by the drip system would have been effective, but such a rate was not studied.

In fertilizing crops where no guidelines on rates have been established for drip irrigation, it is suggested that growers use, as a starting point, a conventional rate and scale that rate downward in field trials to determine the minimum necessary for adequate response. The information provided regarding timing of phosphorus should be applicable to potassium as well.

### **Micronutrients**

Chelates or sulfate salts of micronutrients can be predissolved and metered into drip irrigation systems, but insufficient research has been done on the efficacy of applying micronutrients in such a manner to allow making recommendations.

Growers have encountered some problems with precipitation and emitter clogging when zinc was applied in the sulfate form. There have also

been difficulties in dissolving zinc sulfate for preparation of stock solutions. Chelates are generally highly water soluble and should not cause precipitation or clogging problems. The relatively high cost of chelates, however, has limited their use.

### **Pesticides**

Very little research has been conducted regarding soil pathogen control by application of chemicals through drip systems. In general the findings have indicated that a lack of adequate movement or duration of the chemicals in the soil has prevented effective control of the pathogens.

A number of herbicides have been applied through drip systems for controlling weeds around emitters (Lang *et al.*, 1974). Most of the chemicals studied were adsorbed on soil particles and did not move readily with the irrigation water. Complete distribution of the herbicides through the root zone was not achieved. Also, the herbicides tended to decompose rather quickly in continuously moist soil, reducing their effectiveness.

In other research, EPTC herbicide was studied for control of weeds on twin-row potato beds which could not be cultivated (Phene and Beale, 1976). Several postemergence applications improved weed control without affecting the potato yields. Applications of EPTC at one-half rate were as efficient as at full rate, indicating that it may be possible to improve the efficiency and effectiveness of herbicides by applying them with drip irrigation systems.

# Chapter 6

---

## Clogging and Filtration in Drip Irrigation

Clogging problems are caused by the presence of particles or the development in the system of materials that reduce water flow. Clogging is a progressive problem. Once flow rates are reduced, further clogging is accelerated so that complete stoppage is often an end result. Clogging can occur at any place in the system: filters, lines or emitters. The solution is to introduce clear, clean water and prohibit the development of clogging material in the system.

### Clogging

Clogging agents are divided into three categories—physical, chemical, and biological—for convenience in selecting a corrective treatment.

**Physical.** This group includes the mineral particles of sand, silt, clay, and water-borne debris that are too large to pass through the small openings of filters and emitters. Clay particles can coat filters and inner walls of emitters and reduce water flow. Silt and clay particles may also aggregate in the lines to form masses large enough to clog emitters. Before the filtration system is designed, the water source should be tested for suspended solids content. Such solids should further be identified as inorganic or organic.

**Chemical.** Irrigation waters contain varying amounts of soluble salts that may precipitate on emitters as water evaporates from emitter surfaces between irrigation runs. If the salt does not dissolve readily, a crust can build up which can clog the emitter. High levels of calcium, magnesium, and bicarbonate in the irrigation water favor deposition of carbonates (lime). Saturation with calcium and sulfate ions results in the formation of gypsum in the emitter. Many well waters contain dissolved iron and manganese. Upon contact with the atmosphere, insoluble iron and manganese oxides are precipitated and can clog a drip system. Waters high in sulfides will also produce insoluble compounds. In addition to naturally occurring compounds, precipitates may be formed

from the injection of liquid fertilizers or other chemicals into the system. Mixed liquid fertilizers can be used successfully as long as conditions favoring solubility are maintained. There are simple qualitative tests to identify most insoluble compounds which commercial laboratories can perform. An irrigation water analysis is therefore essential for assessing the probability of chemical deposits.

**Biological.** Micro- and macro-organisms may also clog drip systems. Environmental conditions in drip systems favor the rapid growth of several species of bacteria and algae. Their body masses can become large enough to stop water flow completely. Certain species of bacteria can produce deposits of iron and manganese oxides that add to their clogging potential. Large amounts of such oxides can be produced through biological oxidation processes from waters with very low concentrations of ferrous and manganous ions. Ford (1978) reported that some bacteria oxidize iron when well waters contain more than 0.2 ppm of iron. In some cases, enough iron was precipitated to clog drip systems only a few weeks after installation.

Fresh water crustaceans can be a problem for filter systems. Ants, spiders, and fleas may inhabit emitters and cause clogging. Visual inspection generally identifies these macro-organisms. Microscopic examination is necessary for proper identification of bacterial and algal problems. It may not be necessary to obtain exact identification of microbial masses, but certainly a determination of whether the material is organic or inorganic is important.

### Solutions

Simple treatments are not always successful because many clogging problems are specific to a given set of conditions. Differences among conditions often preclude standardized recommendations. Procedures for correcting clogging problems are now considered according to the type of problem.



**Physical.** In addition to an adequate filter system, regular flushing of the lines and emitters is desirable. Filtration equipment and procedures are discussed later in this chapter.

**Chemical.** Many cases of chemical clogging can be solved by acid treatment or injection. In severe cases, emitters must be soaked in dilute acid solution (~1 percent) and even cleaned individually. For less severe cases, injection of acid to bring the water to a pH between 1 and 2 should be adequate. Injection should be repeated until normal rates of flow from emitters are obtained. The amount of acid required to lower the pH is determined by trials with a small volume of the water. A commercial laboratory can perform the test. Acids are highly corrosive and extreme caution must be observed with their use. Commonly used acids are sulfuric and hydrochloric (Muriatic or swimming pool acid). Choice of one or the other will depend on availability and cost. Acids will corrode metal fittings, pipes, and containers. Surfaces in contact with acid solutions should be of stainless steel or plastic. All such parts must be rinsed well after contact with acid.



Manual emitter flushing.

**Biological.** When bacterial slime or algae clog the drip system, the standard treatment is the injection of a biocide followed by thorough flushing to clear the system of organic matter. Chlorine gas ( $\text{Cl}_2$ ) and hypochlorite solutions ( $\text{HOCl}^-$ ) are the most commonly used biocides. Rates range from 20 to 50 ppm  $\text{Cl}_2$  depending on the severity of the problem and should be maintained in the lines for at least 30 minutes. Chlorine is a very dangerous chemical gas and EXTREME CAUTION must be observed with its use. Chlorine can cause the precipitation of iron and manganese compounds. For that reason injection should be before the filter, but adequate time must be allowed for expected precipitation. A sample of the source water should first be tested with chlorine so that, if necessary, an adequate filter system can be planned. Sodium and calcium hypochlorite solutions are much safer to use and are recommended particularly for smaller systems. Of the several other biocides available, acroleine compounds (Magnacide) have given good results with algae and bacterial slimes. A concentration of 50 ppm of acroleine, used once or twice, oxidizes the organic materials. Acroleine is highly toxic and must be used with EXTREME CAUTION. It may also damage emitters when improperly applied. Choices between the use of chlorine and acroleine depend on cost, safety, and availability.

### Prevention

The following problem-solving procedures are designed to clear systems of clogging agents. Once cleared, systems must be kept clear to prevent further clogging. Ideally, maintenance steps should be initiated at the time systems are installed. They are extra-expense items and often at installation time there is a general feeling that clogging problems won't occur. In most cases, that has proved to be a false assumption.

**Filters.** All filters described in the next section have one thing in common: they must be kept clean to function properly. Backflushing with automatic or manual control valves will keep sand filters and some screen filters clean. Other screen filters are cleaned by removing the screen from its housing and rinsing off the accumulated debris. Some filters are equipped with disposable cartridges which simply require replacement. Special commercial filter systems should be handled according to the specific recommendations of the manufacturer. Pressure gauges are recommended to indicate pressure drop across the filter system. Filter cleaning should be performed as frequently as necessary to maintain the operating pressure of the system within 10 to 15 percent of the

design pressure. An excessive pressure drop through the filter requires more hours of operation for a given volume of water to be delivered, representing an additional energy expenditure, and resulting in lower irrigation efficiency.

**Lines.** It is best to assume that algae and bacteria may eventually grow within the system and establish a regular biocide treatment schedule as part of the system operation. The injectors used are similar to those discussed in the fertilization chapter. Biocides should be injected upstream from the filter so that any reaction products can be kept out of the system. For control of bacteria and algae, a chlorine residual of 0.5 to 1.0 ppm is desirable. The irrigation water must be tested for "chlorine demand" to establish the correct injection rate because some of the added chlorine (either gas or hypochlorite solution) is neutralized by reaction with unoxidized compounds in the water. Only the chlorine in excess of the chlorine demand is available as a biocide. (An equation for calculating rates of addition of sodium hypochlorite is given in Appendix IV of this chapter.) Acrolein is used in maintenance programs at the rate



Sand filters being used in drip irrigation of tomatoes.

of 5 to 10 ppm, injected every irrigation during the last hour or so of system operation.

The capability for flushing the submains and laterals should be part of the system design, and a regular program should be established. The appearance of the flushed water will act as a check on other maintenance procedures. System design should include the means for a regular check of lateral pressures. Lateral pressures should be checked regularly. Clogged lines as well as leaks and line breaks will show up as pressure changes.

All surface pipelines should be black. Enough light can penetrate white PVC pipe to allow algae growth. White pipe should be painted with flat black paint or covered. Do not use paints that can damage PVC pipe.

**Emitters.** The system should be patrolled to observe emitter performance. Any clogged emitters should be flushed in place, if that is possible, or replaced. Individual emitter flow rates should be checked regularly.

Placing the emitter in an upright position helps keep dirt and debris out of the emitter orifice. In some vineyards the emitters are suspended above the ground surface.

## Filtration

For optimum performance, drip irrigation systems must be provided with clean water. An adequate filtration process is an absolute requirement because rarely is a natural water supply free of suspended material. Many types of filter systems are available so that selecting the appropriate filter can be difficult.

**Sand filters.** Sand filters are made up of layered beds of graduated-size sand and gravel or single-size sand. Other types of filter media are also used. Recent engineering design improvements provide sand filters with the capacity to remove all types of clogging agents, in large quantities, with a minimum of inconvenience to the operator. The size and type of sand determine the pore space size and configuration which control the degree of filtration. Pore diameter is approximately 1/7 of the sand particle diameter. Thus, the finer the sand the higher the degree of filtration. Too fine a sand, however, is not recommended because of resultant backwashing problems.

The filtration capability of a sand filter depends not only on sand size but also on the type of sand and the desired flow rate. (See fig. 1. The relationship between sand sizes and equivalent screen mesh sizes is also shown in Appendix I.)

Commercial sands are usually designated by number, becoming finer as the numbers get larger. Sands can be more accurately classified by effective size and uniformity coefficient (see Appendix I). The effective size is a measure of the minimum sand size in that grade while the uniformity coefficient is an indication of the range of sand sizes in the given grade.

Sand filters are cleaned by backwashing, either automatically on a timed cycle or specific pressure drop, or manually.

**Screen filters.** A variety of screen filters is commercially available in many shapes and sizes. The size of the opening, defined by the number of wires per inch, or *mesh*, determines the fineness of filter. Screens finer than 200 mesh are not generally recommended. The relationship between particle size, opening size, and mesh number is given in Appendix I. Commonly used screens are of stainless steel or nylon. While steel screens are stronger, it appears that the flexibility of the nylon aids in the cleaning process. Cleaning of screen filters, usually a manual process, is done by rinsing off or backflushing. Disposable paper cartridge filters are classed here as screen filters, and are very convenient for use with small systems.

**Centrifugal filters.** Also called "cyclone" or sand separators, this type uses centrifugal force to remove particles heavier than water. The filters are generally effective down to fine sand sizes, but only when operated within their specified flow range. They are not effective against algae or very fine precipitates.

**Miscellaneous filters.** There are other types of filter systems commercially available. These should

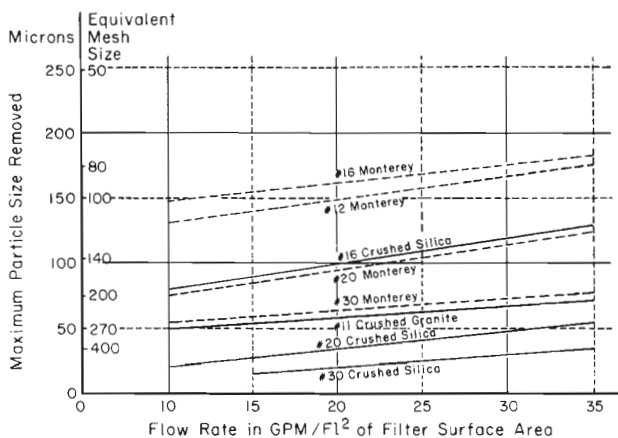

Fig. 1. Filtration efficiency of different grades and types of sand at various flow rates. SOURCE: Yardney, Water Management Products Division.

be examined individually and judged on the basis of proven performance.

**Maintaining the filter.** Filters must be kept clean to be effective. Drip systems are designed for flow rates and water pressures necessary to meet the water needs of the crop being grown. Backflushing, rinsing off, and replacement are standard cleaning procedures, depending on the type of filter. Cleaning should be done whenever necessary, as determined by pressure drop or at intervals determined by previous experience. Screen and paper cartridge filters should be handled with care; denting, piercing, or other damage can make normal operation impossible.

Anything that can be done to lessen the load on a filter will lengthen its life. Many irrigation systems incorporate two or more types of filters in series to ensure adequate filtration. Farm reservoirs are often used as settling ponds so that heavy sand loads can be settled out. However, such reservoirs can be breeding grounds for algae, thus complicating the filtration process.

**Selecting the filter.** The goal in selecting a filter is to achieve the necessary filtration and maximize efficiency of operation (maintenance time, labor, and operator convenience) while minimizing cost. Final selection of a filter should be based on the following guidelines:

- a. Calculate the size of the irrigation system (flow rate in gallons per minute, pressure, and volume of water). The capacity of the filter should exceed the demand of the system.
- b. Determine the physical, chemical, and biological quality of the irrigation water to be used; the size and quantity of suspended solids to be removed; the probability of chemical or biological clogging; and the stability of water quality with time.
- c. Answer these questions:
  - How complex is the filter unit? What problems are involved with cleaning or replacing it?
  - Is labor available for cleaning and maintenance? For large systems, automatic flushing is generally used.
  - Will the location of the filter-unit and disposition of backwash and rinse water be a problem?
  - Is the filtration system flexible? Can it be enlarged or modified if that becomes desirable?

## APPENDIX I.

### Sand size vs. screen mesh

Sand designation number	Effective sand size		Approximate equivalent pore diameter		U.S. series screen mesh designation
	(inches)	(mm)	(Inches)	(mm)	
8	.059	1.50	0.0084	0.214	70
11	.031	.78	.0044	.111	140
16	.026	.66	.0037	.094	170
20	.018	.46	.0026	.066	230
30	.011	2.75	.0015	.039	400

## APPENDIX II.

### DEFINITIONS

**Effective sand size:**

That size opening that will just pass 10 percent of a representative sample of sand, e.g., an effective size of .46 mm means that 10 percent of the sample is finer than 0.46 mm.

**Uniformity coefficient:**

A ratio of the size opening that will just pass 60 percent of a representative sample of sand divided by that opening that will just pass 10 percent of the same sample. (A uniformity coefficient close to 1.5 is usual for commercial sand grades.)

## APPENDIX III.

### AMOUNT OF ACID TO LOWER PH OF WATER

The amounts of acid required to lower the pH of an irrigation water to a given pH can be calculated from the following two equations as either gallons injected per hour of water flow or gallons per 1000 gallons of water. For both equations the acid factor\* and normality of the acid used must be known; e.g., concentrated sulfuric acid (H<sub>2</sub>SO<sub>4</sub>) = 36N; concentrated hydrochloric acid (HCl) = 12N. For equation (1) the flow rate in gallons per minute (gpm) must also be known:

- 1) gallons of acid per hour =  $\frac{0.06 \times \text{acid factor}^* \times \text{gpm}}{\text{acid normality}}$
- 2) gallons per 1000 gallons =  $\frac{\text{acid factor}^*}{\text{acid normality}}$

\*Acid factor = milliequivalents of acid per liter of water required to lower pH to desired level, determined by laboratory titration of water sample with standard acid.

## APPENDIX IV.

### CALCULATION OF REQUIRED AMOUNTS OF CHLORINE MATERIALS

Amounts of chlorine materials required to supply a desired dosage in parts per million chlorine (ppm) are calculated from the percent chlorine in the material (Y), and the water flow rate in gallons per minute (gpm). For chlorine gas assume Y = 100 and calculate as dry material.

- (1) gallons of liquid material per hour =  $\frac{0.006 \times \text{ppm} \times \text{gpm}}{Y}$
- (2) pounds of dry material per hour =  $\frac{0.05 \times \text{ppm} \times \text{gpm}}{Y}$
- (3) gallons of liquid material per 1000 gallons of water (assuming added liquid has same specific gravity as water) =  $\frac{0.10 \times \text{ppm}}{Y}$
- (4) pounds of dry material per 1000 gallons of water =  $\frac{0.83 \times \text{ppm}}{Y}$

## Chapter 7

# Aspects of Drip Irrigation Components— Design and Evaluation

Drip irrigation is the discharge of a low flow of water from small diameter orifices connected to, or a part of, distribution tubings situated on or immediately below the soil surface. The components of the drip irrigation system are, for all practical purposes, similar to those of sprinkler systems. They can be classed into three principal categories: 1) control head, 2) water distribution lines, and 3) orifices or emitters.

### Control head

The control head may consist of flow meters, control valves, chemical injectors, filters, automatic controllers, and sometimes pumps. Normally the control head is at or near the water supply. Because clean water is essential for satisfactory,

trouble-free operation of drip systems, filters are an important part of the control head. Most filtering systems are simple, but some are elaborate, complete with automatic back-flushing devices. The filter must have the capacity for the required water flow and the ability to remove fine particulate matter to sizes several times smaller than the emitter pathways and orifices.

Many commercial installations include two types of filters: sand filters and screen filters using about 200-mesh screens to prevent small foreign matter from clogging emitters. Sand separators can be used in lieu of sand filters to remove sand particles greater than 74 microns in diameter. Sand separators may be installed in the wells at the suction side of the pumps, thus protecting the pumps from sand damage.



Typical drip irrigation control head.

Fertilizers and other chemicals may be either injected into the system by small pumps or placed in a pressure tank and introduced into the system by pressure differential across a venturi orifice or a pressure-reducing valve (see Chapter 5).

Most drip systems require pressure regulation. Pressure for different emitters varies from 2 psi to 30 psi. Pressure regulators are used to control the desired pressure at different parts of the system. Water meters are frequently installed in control heads for precise control of water delivered. Volumetric valves that shut off after a predetermined volume of water has been delivered are sometimes used as part of the control head.

### Distribution lines

The *main lines* deliver the water from the control head to the hose distribution lines. It is important to select lines made from material that will neither corrode nor scale to prevent clogging of the emitters. Normally, PVC, asbestos-cement, or sometimes polyethylene materials are used. Where slopes are irregular or steep, the pipe sizing of main lines should be engineered to regulate pressure.

The *lateral lines* deliver the water from the main distribution lines to the emitters. The emitters can be clipped on the lines or connected to the hose line as a coupler.

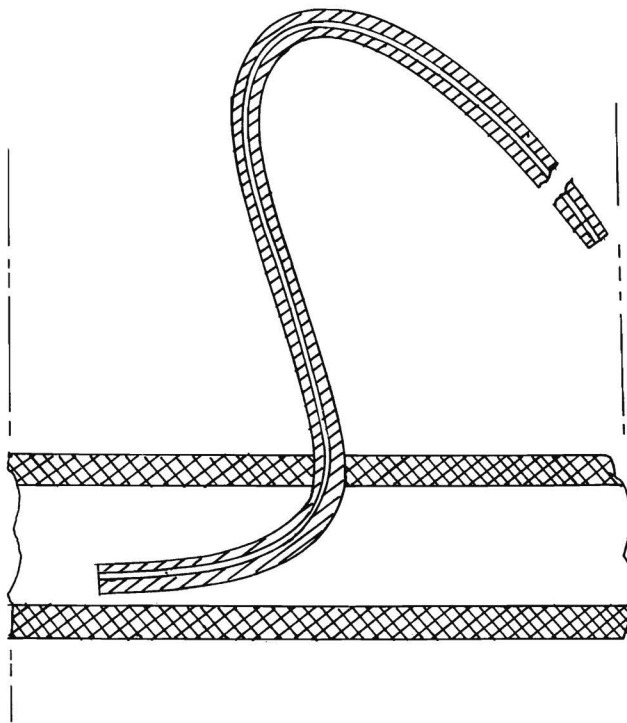

Fig. 1. Cross-section diagram showing microtube and connection to lateral hose line.

Sometimes the emitters are connected to smaller hoses which are attached to the lateral lines with a tee coupler. Such emitter lines are normally made of polyethylene, butylene, or PVC materials and range in diameter from 3/8 to 3/4 inch.

### Emitters

Emitters are mechanical devices that reduce the line pressure to nearly zero, thus applying the water in the form of drops to the soil surface. Emitters vary in type, from perforated pipes and microtubing to complicated designs. Rate of flow from the emitters at a typical operating pressure of 10 psi is normally fixed, ranging from 1/2 to 2 gallons per hour. There are six types of emitters: microtubes, long path emitters, short-orifice emitters, vortex emitters, pressure compensating emitters, and porous pipe or tube emitters.

*Microtubes* are the original forms of drippers. They consist of very small-diameter tubes of variable length made of high density plastic tubing, connected to a lateral. The internal diameter of microtubes ranges between 0.020 to 0.040 inch, although other sizes are sometimes used. For a variety of pressures, a wide range of delivery rates can be obtained by changing the length of the microtubes. A long tube increases the resistance to flow and, conversely, the flow rate can be increased by shortening the microtube.

*Long path emitters* are similar in design to microtubes. They consist of a long path channel wound in a coil shape or cast in a zig-zag shape

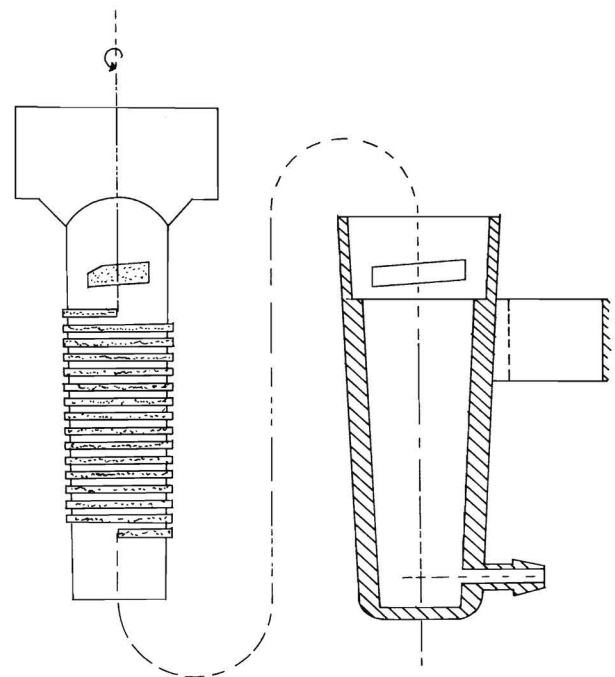

Fig. 2. Cross-section of typical long path emitter.

with one end inserted into the lateral line while the free end releases the water in drops. Some are made of plastic material cast around a cylinder to produce the path length desired and covered with a cap provided with barbs or other types of hose connections. The flow rates of such emitters are fixed at ½ to 2 gallons per hour.

*Orifice emitters* are plastic laterals with perforated holes of very small diameter (0.004 inch) from which water drips at a rate of ½ to 2 gallons per hour under operating pressure of 1.5 to 7 psi. Uneven flow through the holes, which is caused by continuous change in the plastic, has been reduced by several manufacturers who have developed devices to insert in the orifices. The flow at the outlet is controlled by a movable ball-shaped shutter which can block all flow except that which passes through a small groove which determines the water flow. Orifice emitters are sometimes described as self-flushing emitters because the design allows a high volume of water to flow through the chamber briefly, flushing out some of the particles in the system. When the system pressure reaches the level for which it was designed,

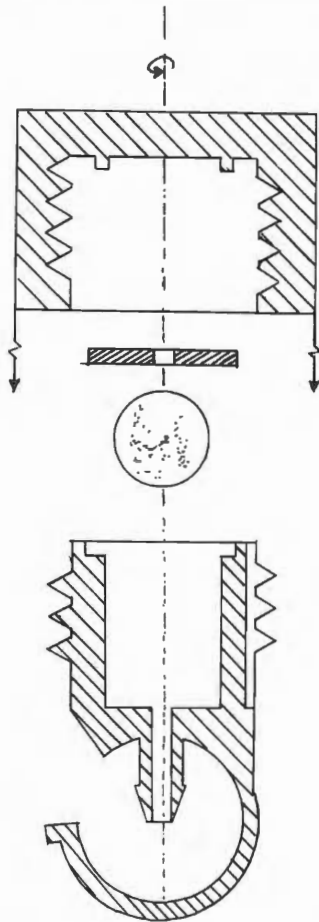
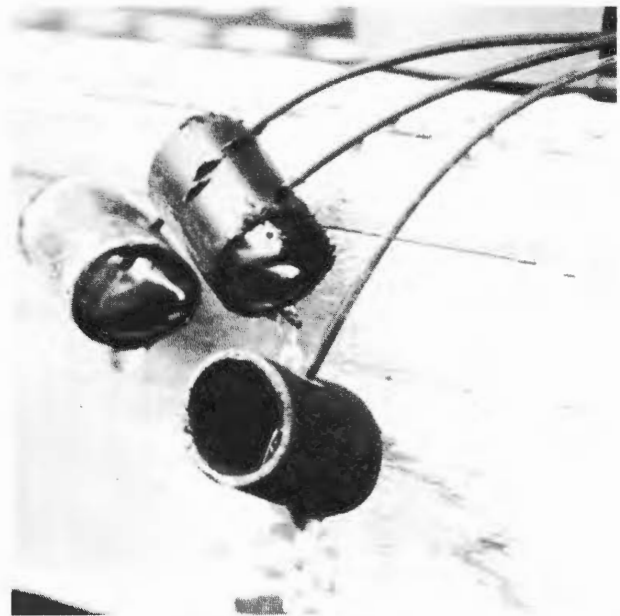

Fig. 3. Cross-section of orifice emitter device with ball and diaphragm to regulate flow.

the moving ball finally settles in its chamber, restricting the flow appropriately. At times orifice emitters have not performed well due to the accumulation of calcium, fertilizers, or organic deposits which change the characteristics of the flow paths.

*Vortex emitters* are similar to orifice emitters but with several design variations. The water from the lateral lines enters the chamber at a high velocity through a small hole cast tangentially to the direction of water flow. The introduced water strikes the circumference of the chamber causing a whirling action at a high speed which ultimately subsides, allowing water to flow through an outlet.



Microtube emitters commonly used in irrigation of potted plants in nurseries.

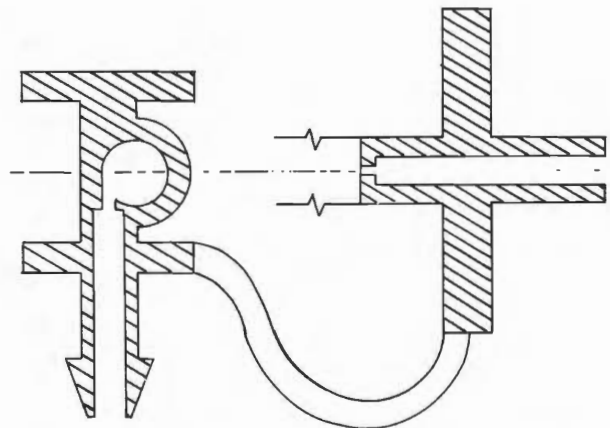

Fig. 4. Cross-section of vortex type emitter showing turbulent-flow chamber.

The vortex action is believed to produce turbulent flow that causes limited self-flushing and some pressure compensation.

*Porous pipes or tapes* discharge water throughout their entire length. They are used primarily in row crops. The tubing is generally made of polymer compounds with small pores from which the water seeps. The tubing is often buried 2 to 4 inches and is particularly sensitive to clogging problems. Complete filtration of the water is absolutely necessary for proper operation of porous pipes or tapes.

### System design

The potential for control of water application through drip systems can only be realized through a well-planned, sound design. Precise design of drip systems seems justified for at least two reasons: the low operating pressures of drip systems require that pressure losses within the system be kept to a minimum if high uniformity of application is desired; and the capital cost of a permanent system can be minimized through good engineering design. (A detailed description of drip irrigation design is beyond the scope of this publication. Refer to I-Pai Wu and H. M. Gitlin, 1973, 1974,

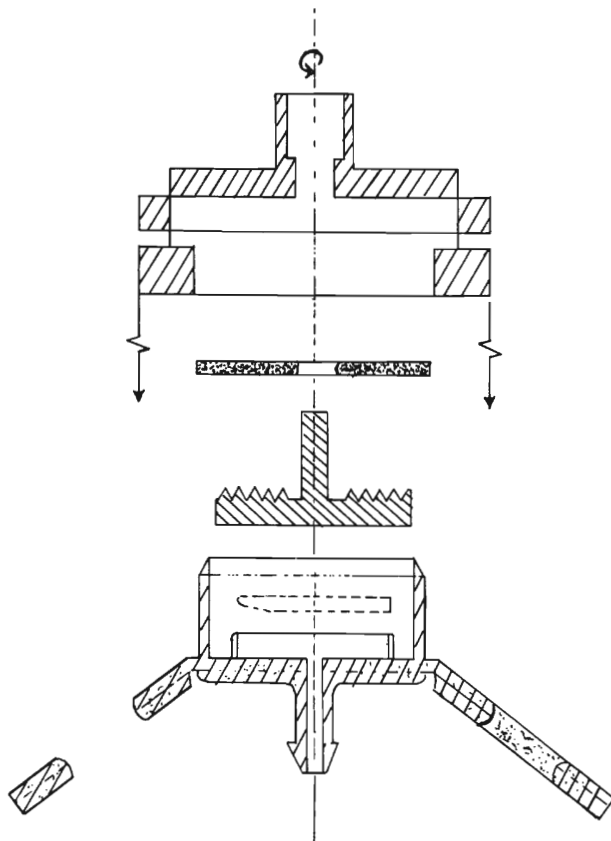

Fig. 5. Cross-section of pressure-compensating emitter with flexible diaphragm to regulate flow.

1975, and Keller and Karmeli, 1974, for further reading.) This section will discuss various aspects of the functional design of drip systems in California, and will provide an example of drip irrigation design using microtube emitters, which are popular in small, self-installed systems.

Final design of an irrigation system requires knowledge of many characteristics of the soil, irrigation water, climate, and crop to be irrigated. An important consideration is the design capacity of a drip system, which, as with any other irrigation system, must have the capacity to meet the peak or maximum crop evapotranspiration (ET) demand.

Peak ET demand data for several drip irrigated crops in California is presented in Chapter 4. That chapter also discusses the potential reduction of ET due to localized irrigation. It is suggested that no modification be made involving the ET of full-cover crops developed under conventional methods of irrigation because experimental evidence indicates that, under full-cover conditions, crop transpirational losses (which are nearly independent of irrigation method) dominate the ET process and evaporation from the soil under conventional irrigation techniques is only a small fraction of the ET (less than 10 percent).

Once the peak ET demand is known, an adjustment has to be made based on irrigation efficiency because drip irrigation, like any other system, is not 100 percent efficient. Typical design efficiencies for drip irrigation range between 80 and 90 percent. The net irrigation requirements (peak ET) divided by the assumed efficiency (0.8 or 0.9) yields the gross irrigation requirements upon which the continuous flow rate required must be calculated.

**Example 1.** The "normal"\* peak ET for deciduous orchards in the Sacramento Valley is 0.24 in/day in July. Assuming an application efficiency of 0.9, the irrigation requirements will be  $0.24 \div 0.9 = 0.27$  in/day, which is equivalent to 5 gpm per acre of continuous flow, 24 hours a day. However, drip systems should not be designed to operate continuously during peak demand. Some designers use a maximum of 20 hours a day, others use from 12 to 18 hours. The additional time should be considered reserve time in case repairs are needed or other problems arise. If the system is to operate 18 hours a day, the continuous flow required should be:  $5 \text{ gpm/acre} \times 24/18 = 6.7 \text{ gpm/acre}$ .

Whereas that will be the flow required to meet the ET demand of a mature orchard, systems

\*NOTE: Values considerably higher than 0.24 in/day are common. Each system should be designed to meet the maximum expected peak ET, based on past climatic data, which may differ considerably from the value used in this example.



for newly planted orchards should be engineered to meet increasing water requirements by adding emitters to each tree as it grows. (Data on ET of young trees are given in Chapter 4.) Generally, newly planted orchards are started with one or two emitters per tree, and the number increased to four when the trees are three to four years old. Mature trees may require six or even eight emitters, depending on wetting patterns (see Chapters 2 and 3). In any case, the system should be engineered from the control head to the lateral eventually to be able to meet the peak ET demand as discussed above. Sometimes it is easier to lay out another lateral per tree row as the need for additional emitters increases with tree growth.

The number and flow rate of emitters can be calculated on the basis of peak ET demand. Knowing the gross irrigation requirements in inches per day, one can determine the value of water in gallons per tree per day (R) with this equation:

$$R = 0.623 \times C \times A,$$

C being the peak ET in inches per day and A the area (square feet) that a single tree occupies.

**Example 2.** If trees are planted 24 × 24 feet and the gross irrigation requirements are 0.27 inches/day, then

$$R = 0.623 \times 0.27 \times 24 \times 24 = 96.9 \text{ gallons/tree/day.}$$

If six emitters are needed, the flow to be delivered by one will be  $96.9 \div 6 = 16.1$  gallons. A 1-gallon-per-hour emitter will deliver that amount in 16.1 hours.

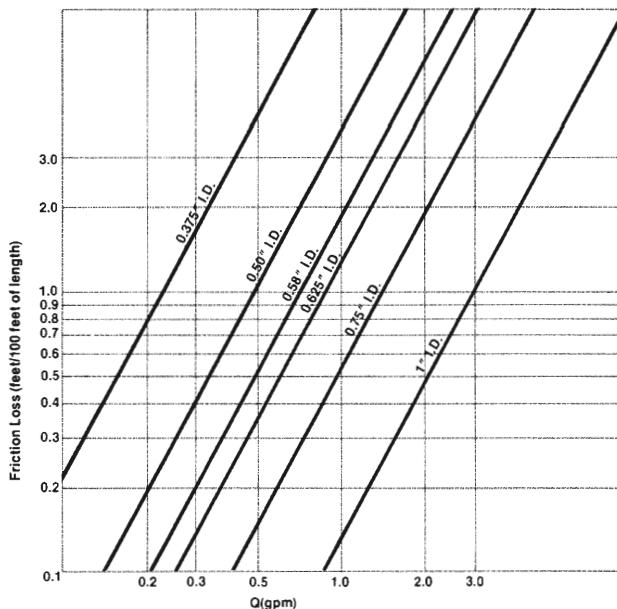

Fig. 6. Friction losses in polyethylene drip laterals calculated from Hazen-William's formula (C = 130).

## Lateral design

The lateral line is the critical point where flow, diameter, and operating pressures are adjusted to insure uniform distribution of water. Once the emitter design discharge and operating pressure have been determined, the length, diameter, and friction losses in the lateral can be calculated.

Many criteria have been developed for determining tolerance limits for uniformity of water application through drip systems. It is commonly assumed that the laterals should be designed so that differences in flow rates between the first and last emitter should not exceed 10 percent of the emitter design output. In view of the manufacturer's tolerance in emitter discharge and the uncertainties in the estimates of crop ET requirements, that criterion seems adequate. A 10 percent difference in flow rate may mean 10 percent difference in operating pressure for emitters with laminar flow regime or as much as 20 percent pressure difference for fully turbulent flow emitters.

Elevation differences must be considered when the irrigation system is installed on sloping ground and the lines do not follow the surface contours. Such differences must be added to the friction losses if the flow is upslope and subtracted if the flow is downslope.

When the two losses exceed the allowable head loss or the available pressure head, the lateral must be shortened and additional submains added.

The following is an example of lateral design that incorporates microtube emitters. The procedure—

- A. Determine lateral length, and number and flow rate of emitters.
- B. Determine lateral diameter based on maximum allowable friction loss and calculate actual friction loss in the lateral.
- C. Determine the pressure distribution using Figure 7 and elevation differences along the lateral length. Using those data, calculate the

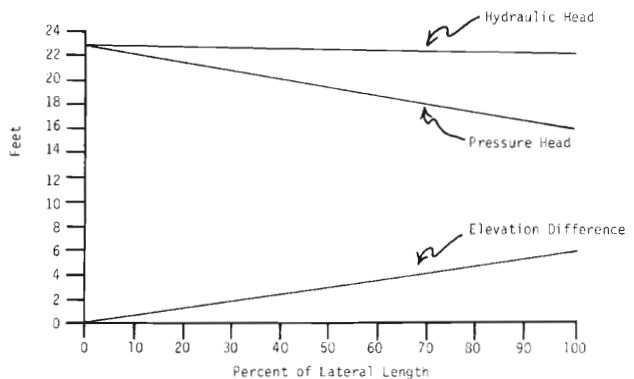

Fig. 7. Distribution of pressure head and hydraulic head and elevation changes in lateral.

pressure head distribution along the lateral length. The hydraulic head is the sum of the pressure head and elevation difference at any particular point along the lateral. The elevation difference is added to the pressure head for increases in elevation, and subtracted for decreases in elevation.

- D. Based on the plot of available hydraulic head versus lateral length, select microtube lengths such that the friction loss in the microtube will dissipate the available energy at each lateral section.

**Example 3:** Lateral design using microtube emitters.

A. Emitter characteristics and lateral length

Design discharge = 1 gph  
 Operating pressure = 7 psi (7 × 2.31 feet/psi = 16.2 feet)  
 Emitter spacing = 6 feet  
 Lateral length = 240 feet  
 Laterals are to run uphill with 2.5 percent slope  
 Total number of emitters: 240 ÷ 6 = 40  
 Total flow rate in lateral: 40 gph ÷ 60 = 0.67 gpm

B. Friction losses in lateral

From Figure 6, we obtain the friction loss for the commercial ½-inch polyethylene hose for the flow rate of 0.67 gpm, which is J = 0.9 feet/100 feet.

Given the lateral length and the number of outlets, the total friction loss in the lateral may be calculated as follows:

$$\text{Total friction loss in lateral} = \frac{240 \times 0.9}{100} = 2.2 \text{ feet}$$

However, we need to correct for the fact that as the flow rate diminishes along the length of the lateral, the friction loss decreases. (A correction factor for the flow rate reduction is given in Table 1.)

For this example, the correction factor for 40 emitters is 0.35. Therefore, actual friction loss in the lateral is 2.2 × 0.35 = 0.8 feet. That is less than the maximum allowable change of operating pressure along the lateral length, which is 10 percent of the required pressure head, or 1.6 feet. (A smaller diameter, 0.5 inches ID, was tried but had a friction loss

**TABLE 1.**  
 Factors by Which the Friction Loss in Laterals Must Be Multiplied to Correct for the Number of Emitters

number of emitters	5	10	20	30	40	50	100
factor	0.44	0.39	0.36	0.35	0.35	0.34	0.34

SOURCE: Adapted from Christiansen, 1942.

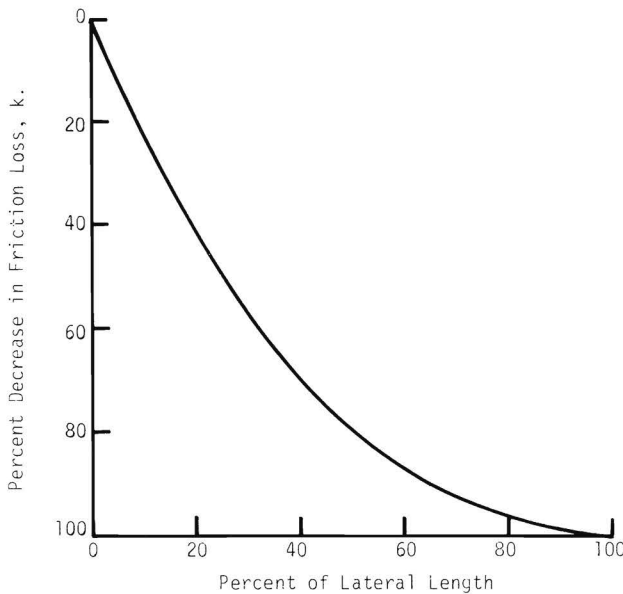

**Fig. 8.** Distribution of friction losses in drip laterals. (SOURCE: Adapted from Wu and Gitlin, 1975.)

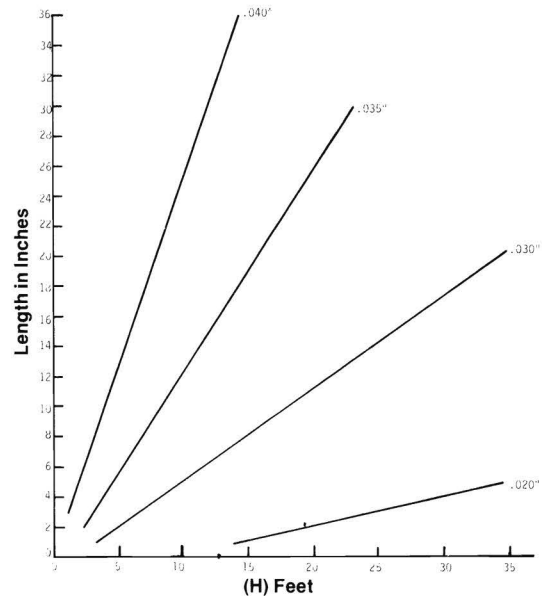

**Fig. 9.** Relationships between high density polyethylene microtubing length and operating head (H) for a discharge of one gallon per hour under various microtube inside diameters (0.020, 0.030, 0.035 and 0.040 inches).

greater than the maximum allowable. Therefore, 0.58 inch inside diameter polyethylene pipe was selected with a friction loss of 0.8 feet.)

C. Computation of elevation differences based on the given slope

$$z = 2.5\% \times \frac{240}{100} = 6.0 \text{ feet}$$

D. Pressure head distribution

Pressure head required at the last emitter was  $h_2 = 16.2$  feet. (This is determined by the design pressure of the system.) Therefore, pressure head required at the lateral entrance,  $h_1$ , is

$$h_1 = h_2 + \text{friction losses (0.8 feet)} + \text{elevation differences (6 feet)} = 23.0 \text{ feet}$$

Changes in friction losses along the lateral can be determined from Figure 8. The pressure head distribution can then be determined from

$$h_p = h_l - (h_f \times k) \pm h_e$$

- Where  $h_p$  = pressure head at any location  
 $h_l$  = pressure head at lateral entrance  
 $h_f$  = friction loss in lateral  
 $k$  = multiplier obtained from Figure 2 (expressed as a decimal instead of as a percentage)  
 $h_e$  = elevation difference between lateral entrance and location in question. ( $h_e$  is positive for decreases in elevation and negative for increases in elevation.)

**Example 4.** Calculate the pressure head at 120 feet (50 percent of the lateral length).

$$\begin{aligned} h_l &= 23.0 \text{ feet} \\ h_f &= 0.8 \text{ feet} \\ k &= 0.8 \text{ (from fig. 2)} \\ h_e &= 3.0 \text{ feet } (2.5 \times \frac{120}{100}) \end{aligned}$$

Therefore  $h_p = 23 - (0.8 \times 0.8) - 3.0 = 19.4$  feet.

By using the pressure head distribution and Figure 9, lengths can be selected for each location along the lateral. The results are given in Table 2.

A simplified procedure may be followed when only approximate solutions are desired. This procedure is based on using the pressure head calculated at the lateral entrance and at the last emitter. The maximum and minimum pressure head values are entered in Figure 9 and microtube lengths are obtained. For the example above—

$$\begin{aligned} h_1 &= 23 \text{ ft} & h_2 &= 16.2 \text{ ft} \\ L_1 &= 30 \text{ in} & L_2 &= 21 \text{ in} \end{aligned}$$

So microtube lengths should start at 30 inches and uniformly decrease to 21 inches for the last emitter.

When the sum of the friction losses and elevation differences does not exceed 10 percent of the operating pressure, microtube lengths may be the same throughout the lateral because under field conditions the decrease in hydraulic head along the lateral is compensated for by a decrease in the viscosity of water resulting from an increase in the temperature of water along the lateral. The viscosity decrease lessens friction losses through microtubes, offsetting the decrease in hydraulic head.

To insure uniform pressure among the lateral lines, it may be necessary to control the pressure into the lateral line by flow control devices. Such devices include simple disk orifices, flexible control disk type orifices, flow control tubing, and pressure regulators. In some cases, where pressure control is difficult or expensive to achieve, microtube emitters should be used and calculations should be run for the various lateral situations.

After the lateral has been designed, manifolds and main lines may be sized using friction loss tables such as those given in Division of Agricultural Sciences Leaflet 2908, "Low-Head Irrigation Pipe: Concrete, Asbestos-Cement, Plastic." Total flow rates, total hydraulic head, and pressure head should be computed up to the control head where the friction losses due to the filtration and chemical injection equipment should be added. The resulting pressure head and flow rate can then be considered in selecting an appropriate pump.

### Evaluation of drip irrigation systems

Well-designed drip irrigation systems must be properly managed for successful operation. Periodic evaluations of system performance are perhaps more essential under drip irrigation than under other methods because of the clogging problems associated with drip systems (Chapter 6). Any evaluation of irrigation practices has to answer

TABLE 2.  
Emitter Length Required for Various Pressure Heads.

Tree number*	Average pressure head (feet)	Emitter length (inches) (1 gph, 0.035")
1	22.5	29.5
2	21.6	28.0
3	20.8	27.0
4	20.1	26.2
5	19.4	25.2
6	18.9	24.5
7	18.4	24.0
8	17.7	23.0
9	17.0	22.0
10	16.2	21.0

\*There are six emitters per tree. It is assumed that the pressure head is the same for all six emitters. Therefore the first emitter should be 29.5 inches long, the second, 28, and so on.

two questions: Is the amount of water applied adequate? Was the water uniformly applied?

The following is a procedure to evaluate the adequacy and uniformity of irrigation in a drip system based on methods proposed by Keller and Karmeli (1974) and Merriam and Keller (1978).

- I. Check to see that the system is operating normally.
  - A. Assess the condition of filter screens and check that no emitters are clogged.
  - B. Check operating pressure.
  - C. Note water use rate for the block being tested.
  - D. Note design operating pressure and the corresponding discharge rate, frequency, and length of irrigation cycle.
- II. Obtain equipment to measure discharge rates of emitters:
  - A. stopwatch or wristwatch with clearly visible second hand;
  - B. 250 ml graduated cylinder;
  - C. funnel, 3 to 6" diameter;
  - D. flasks or beakers to collect water; and
  - E. trough 3 feet long for use on porous tubing or perforated hose system to measure flow of 3-foot length of tubing. (Cut 1 or 2 inch diameter PVC pipe in half lengthwise.)
- III. Select block and begin testing.
  - A. The evaluation should be conducted for several laterals. It is common to select four laterals where high, low, and average flows are expected, situated within the system as follows:
    1. near the manifold inlet;
    2.  $\frac{1}{3}$  distance along manifold from inlet;
    3.  $\frac{2}{3}$  distance along manifold from inlet; and
    4. the lateral farthest from manifold inlet.
  - B. Select at least four plants along each lateral where high, low and average flows are expected, situated as follows:
    1. near the lateral inlet;
    2.  $\frac{1}{3}$  distance along lateral from inlet;
    3.  $\frac{2}{3}$  distance along lateral from inlet; and
    4. the plant farthest from lateral inlet.
  - C. Evaluate emitter discharges for each plant.
    1. Collect water from all emitters supplying individual tree or plant.

2. Use whole-minute intervals when collecting volumes.
3. Average the volumes collected and record value for each plant.
4. Convert milliliters per minute to gallons per hour:

$$\frac{\text{ml/min}}{63} = \text{gph}$$

5. If porous tubing is used, use 3 ft. trough and collect volumes. (No averaging is necessary since the collection is made from 3-ft. sections. Only one measurement per lateral may be necessary depending on its length.)
- D. Compute 2 averages from values acquired in III-C.
    1. Determine the average individual tree emitter discharge.
    2. Compute the average of the lowest 25% of the tree emitter discharges. This is considered the minimum rate of discharge per plant.
  - E. Compute emission uniformity (E.U.)—the parameter that indicates the uniformity of distribution defined as:
 
$$\frac{\text{Minimum rate of discharge per plant}}{\text{Average rate of discharge per plant}} \times 100 =$$

$$= \% \text{E.U.}$$

E.U. value rating

    - a. + 90%—excellent
    - b. 80-90%—good
    - c. 70-80%—fair
    - d. - 70%—poor
- IV. Check adequacy of irrigation.
    - A. Compute the volume of water applied to the average tree:
 
$$\text{gallons/tree/day} = \frac{N \times \text{gph} \times \text{hours}}{\text{days}}$$

where

N = number of emission points  
 gph = average emitter discharge in gallons per hour  
 hours = length of irrigation cycle  
 days = days between irrigations
    - B. Check the figures of applied water obtained in IVA against the crop water requirements given in Chapter 4.

# Chapter 8

---

## Other Methods of Localized Irrigation

A salient feature of permanent or solid-set irrigation systems is that they permit frequent application of small quantities of water. This is impractical with most surface systems because a labor cost is associated with each irrigation. Furthermore, permanent systems can apply water directly to the areas where it is to be consumed rather than requiring it to flow overland. This places control of infiltration rate and distribution uniformity directly in the irrigation system. Soil properties always control infiltration rate and uniformity with surface irrigation systems.

Permanent systems can be classified into two groups: pressure systems, such as drip, spray, spitter, mini-sprinkler, and sprinkler, which control flow at each outlet by friction loss through an orifice or some other kind of emitter; and a newly developed gravity flow system, the low-head bubbler, which controls flow by the elevation of each outlet.

### Pressure systems

Of all the pressure systems, drip irrigation has the lowest flow per outlet, a feature which has both advantages and disadvantages. A major advantage is that the low flow rate permits the use of small-diameter tubes as laterals. For sparsely planted crops such as orchards, this greatly reduces the cost of tubing as compared, for example, with sprinkler irrigation. But the low flow rate means the system must operate much of the time, requiring a nearly continuous water supply.

For densely planted crops the limited radius of distribution from each emitter requires a greater number of emitters. The increase in number of emitters and increase in lateral length tend to offset the low unit cost. The conflicting demands of low emission rate and reasonably high lateral pressure to compensate for undulations in ground level also require either small diameter orifices or somewhat larger, but more expensive, tortuous path or turbulent flow emitters, necessitating

either filtration or expensive emitters, and again offsetting the cost advantage of the low-flow drip system.

Increasing the flow capacity of a system and using small spray or mini-sprinkler emitters rather than drippers can overcome the disadvantages of drip systems. The higher flow rate per unit area allows the crop to be irrigated in a shorter time, reducing the need for a continuous water supply. The increased distribution radius of sprays or sprinklers reduces the number required and the larger orifices reduce the need for filtration to prevent clogging. But such advantages come at the expense of increased lateral pipe diameter. Two additional advantages of spray systems are an increase in the wetted soil volume as compared with drip systems and a decrease in the labor needed to check emitter operation. Furthermore, some high flow rate spray, spitter, or fogger nozzles may actually apply less water per unit area than low flow rate emitters, simply because they spread the water further. Therefore they are suitable for localized irrigation of low intake rate soils.

Sprays, spitters, foggers, and mini-sprinklers are available with flow rates extending from about 4 to 50 gph at heads ranging from about 12 to 70 feet (5 to 30 psi) and wetted diameters from 6 to 30 feet. Those flow rates fill the gap between drippers and conventional sprinklers. At the higher flow rates the additional possibility of using the irrigation system for frost protection can help justify its increased pipe size. Evaporation losses from areas irrigated by spray are likely to be higher than those from conventional drip systems because more surface area is wetted by the foggers than by drippers.

Because no one system is best for all applications, choosing the least costly and most effective system for any specific crop and area turns out to be a study in trade offs. One of the trade offs is between pipe size and distribution uniformity. Because flow rate from all of the emitters described here is pressure dependent, increasing the pipe size,

thereby decreasing the friction loss along lateral lines, can help reduce the pressure variation. But the cost for pipes capable of handling such pressures increases significantly with pipe diameter.

As the flow capacity of a system increases, the time it must operate decreases. Two choices are open. The system can be alternately turned on and off—pulsed—to simulate a continuous low application rate; or it can be operated less frequently, with larger applications at each irrigation. The choice will depend on costs as well as topography and soil properties. Pulsed systems require automatic controls and valves which increase the cost. Also, if the system is installed on a grade, drainage of lateral lines through downhill outlets can distort the distribution uniformity of pulsed systems. Check valves installed in the laterals can reduce the drainage, but add to the cost.

Recently, travelling drip systems have been designed and several prototypes are being tested under field conditions. A travelling boom, sometimes using components from center pivot irrigation equipment, moves above the crop delivering water to each row through orifices and plastic pipes of small diameter that reach near the ground. Because the application rate usually exceeds the



A low-head bubbler system in use in citrus orchard.

intake rate of the soil, small basins of blocked furrows are formed for surface water storage. These systems show promise in allowing efficient localized irrigation with lower energy requirements.

### Low-head bubbler

By reducing the pressure requirements, a newly developed low-head bubbler system allows pipe diameter to be increased at least cost by permitting thin-walled low-head pipe to be used. The pressure normally required to mask flow variations resulting from undulations in ground level is eliminated by adjusting the elevation at each outlet to control the flow. This fixes the flow precisely at each outlet, eliminating distribution non-uniformity resulting from either friction loss along the lateral or variations in ground level.

A typical system for orchards consists of 4-inch-diameter corrugated plastic pipe buried between every other row, 550 feet long. (This is the same thin-walled pipe used for drainage systems, except it is not perforated.) Lengths of smooth-wall, 3/8-inch ID plastic drip hose deliver water from the lateral to the trunk of each tree on both sides of the lateral. With a flow rate of 1 gpm to each tree, the head loss along a 550-foot lateral is less than 2 feet. Flow to each tree is controlled simply by adjusting the elevation at the outflow end of the 3/8-inch hose that is attached to the trunk. Decreasing the elevation along the lateral compensates for head loss in it. This simple system distributes water uniformly to each tree without pumps, filters, and sophisticated flow-regulating devices.

The 3/8-inch hoses are attached to the corrugated pipe by cutting a 1/8-inch hole in the ridge and enlarging it with a tapered tool. The hose is inserted immediately after the tool is withdrawn. The stretched plastic surrounding the hole shrinks around the hose, clamping it tightly and forming an excellent seal.

The hoses delivering water to each tree are pulled through holes made by a jetting pipe inserted at an angle from the tree trunk to the wall of the lateral trench by use of air or water pressure. The hose is attached to the end of the pipe and pulled into the hole as the pipe is withdrawn.

The proper elevation of the hose outlet end at each tree to provide equal flow rate is easy to determine. One way is by standing water at a fixed static head in the lateral. A reference level can be found and marked on each tree by lowering each supply hose until the water level stands at its opening. During the procedure, all other hoses are kept elevated so that water does not flow from them. All subsequent elevation measurements are made relative to this reference elevation. Next, the head that will be lost within the lateral between each

pair of hose connections when the system is operating is calculated from the design flow rate. The hoses are then attached to each pair of trees along the lateral at decreasing elevations to compensate for the head loss. Experience has shown that that procedure alone gives an emission uniformity of about 90 percent. Readjusting the hoses with the system operating increases the uniformity to about 98 percent. The readjustment is done by raising each hose, one at a time, to the point where water ceases to flow, and then measuring down from that point a distance equal to the desired head loss across the delivery hose and relocating the hose outlet at the new elevation. Such a dynamic calibration assures that each delivery hose has the same head loss across it, thereby eliminating errors introduced by imprecise estimates of head loss in the lateral.

The delivery hose can be conveniently attached to each tree with a plastic, barbed "tee" fitting stapled to the trunk with its side outlet at the desired outflow elevation. The delivery hose is then connected to the bottom and an additional length of drip hose is attached to the side outlet to conduct water away from the tree trunk. The upper outlet of the tee draws air, breaking the siphon, which maintains the effective outflow elevation at the side outlet regardless of the actual elevation of outflow from the hose attached to it. A short

length of hose attached to the upper outlet of the tee allows a small head to build momentarily when the system is turned on to flush any air blockages from the hose attached to the side outlet.

The cost of materials for the irrigation system will vary with the distance from manufacturing plants. As of 1980, the cost at Riverside, California, for corrugated tubing, connectors, and drip hose was approximately \$250/A for a system using 3-inch ID corrugated pipe and \$300/A for 4-inch ID pipe. Commercial installation costs are difficult to estimate from experimental systems, but may be less than \$500/A. The costs are generally comparable to or lower than many complete drip irrigation systems, including pumps and filters. The longer life of a completely buried system and the lower energy requirements may make this closed-conduit, gravity system an attractive alternative, particularly for relatively level fields that can be converted from surface irrigation methods.

The low-head bubbler has the additional advantage of significant savings in pumping costs. It can be operated frequently with small basins or infrequently with larger basins. As long as the water applied is the correct amount, is the same to each plant, does not exceed the water storage capacity of the soil, and is within the reach of the roots, the frequency of irrigation can be that which is most convenient.

## Chapter 9

# Drip Irrigation of Avocados in San Diego County: A Case Study

The "Drip Irrigation Avocados Experiment" in San Diego County was the first drip irrigation experiment in California on a commercial scale with a tree crop. The experiment was set up to compare a drip irrigation system with a sprinkler irrigation system on newly planted avocado trees and was conducted from June 1, 1970 until September 1, 1976.

Irrigation is the most important cultural practice in growing avocados. Water conservation should be an important part of every grower's job. Not only is the price of water particularly high in San Diego County (as high as \$200-250 an acre-foot in 1980), but there is also a limited amount available. For many years work has been underway to improve the irrigation methods and techniques for growing avocados. Basins, furrows, and fixed and rotating sprinklers were the irrigation methods used. As water became higher priced and as labor became more expensive, and in some cases unavailable, the grower had to refine as many of his cultural operations as possible. Attempts were made at automating irrigation systems. Tensiometers were used to better understand soil moisture conditions and their relationship to tree performance. Drip irrigation offered a refinement of previous irrigation techniques under the hilly conditions of many groves, and it was with this in



Drip irrigation of avocados in San Diego County.

mind that an attempt was made to introduce drip irrigation into avocado orchards of San Diego County.

### General description of project

A drip irrigation experiment on avocados was initiated in the fall of 1969. In June 1970 the orchard was planted, and the irrigation system installed. The experimental site is situated on the Trendel orchard near Bonsall in north San Diego County. Bonsall is at the center of 12,000 acres of avocados—25 percent of the state's avocado acreage.

The test orchard has an area of five acres, divided into eight plots. Four plots were irrigated with fixed sprinklers and four plots with drip emitters. The number of trees in each plot varies but the average ranges between 60 and 75.

The orchard was originally engineered for a conventional sprinkler system. Buried rigid PVC pipe for mains, sub-mains, and laterals were in place at the time the trees were planted. The drip system was superimposed on the permanent irrigation system in the four plots that were to be drip irrigated.

Two varieties, Hass and Reed, were selected by the grower for planting. Both are Guatemalan type, summer producing, and somewhat sensitive to frost. Tree spacing for both varieties was 15' × 20'. Each plot was split and contained about the same number of trees of each variety.

The soils in the orchard consist of a complex of two well-drained soils: Fallbrook fine sandy loam, and Vista sandy loam. The soil depth ranges from 20 to 60 inches. The pH ranges from 6 to 7.2. The orchard has a slope of about five percent and is at an elevation of about 600 feet. Annual precipitation ranges from 12 to 20 inches, and air temperature ranges from 24 °F to 102 °F.

The water used on the experiment was from the Colorado River. The avocado tree is sensitive to salts, especially chloride. The total salts in Colorado River water is equivalent to 1 mmho, or 750 ppm; the chloride content is approximately a



hundred ppm. These are levels at which considerable caution should be used in irrigation management. Frequent irrigations with periodic leaching are necessary in areas with such highly saline water to move the salts through the soil profile and below the root zone; otherwise, tip burn will occur on the older leaves in the fall and winter.

Measurements taken during the course of the experiment on a weekly, monthly, and annual basis included: 1) tensiometer readings; 2) water evaporation from the Class "A" pan situated adjacent to border trees on the east side of the plot\*; 3) uniformity of flow from different emitters along the line; 4) water meter readings to determine water applied on sprinkler and drip plots; 5) soil salinity; 6) leaf chemical analyses; 7) height and width of trees; 8) circumference of trunk below and above the bud union; 9) root growth patterns; 10) soil moisture patterns; and 11) fertilizer distribution throughout the irrigation system.

## Results

Canopy size (Table 1) did not differ between the two methods of irrigation over the five years of study. The only significant differences among trees were related to varietal differences.

Fruit yields were exceptionally high—over 1000 pounds per acre the first harvest in 1973 and about 10,000 pounds per acre in 1975. Yields were higher in the sprinkler-irrigated plots than in the drip-irrigated plots in the last two years of the study (1975 and 1976). The difference appears to be related to the insufficient soil volume wetted by the four emitters rather than to insufficient applied water. It is now recommended that each tree be irrigated with six emitters.

Water applied was volumetrically measured in each plot. Separate water meters for the drip- and sprinkler-irrigated plots were read weekly. From those readings the amounts in gallons per tree and acre inches per acre were calculated. The meters recorded the total water applied to 325 trees by sprinklers and 349 trees by drip. Each tree was provided, but did not fully cover, 300 square feet of land area.

Table 2 shows the small amount of water needed by very young trees and the rate at which water use increases as the trees grow. The comparison of water applied to drip plots with the amount applied to sprinkled plots shows a change in ratios as the trees grow larger, from 31 percent as much water for drip-irrigated trees the first year to 75 percent as much the last full year of the experiment (1975). The early low used by drip irrigation was probably caused by the low evapor-

\*This is not the standard environment recommended for setting the pan but was the best available.

ation loss from the small areas of soil wetted when the trees were small. Sprinkled plots had a greater area of wet surface soil from which water evaporated. As the trees grew and shaded more of the soil, a larger proportion of the water applied to sprinkled trees was applied to drip-irrigated trees.

While the ratio of water applied by the two methods changed with tree growth, the difference between the two, caused mainly by evaporation from wet soil, remained fairly constant, ranging from 4 to 5.5 inches per year in the first 3½ years. In June 1974, the sprinklers were changed from fixed jet to reaction type rotating sprinklers which wetted a much greater area. The new sprinklers increased the losses by evaporation and possibly by deep percolation into soil that roots had not yet penetrated. The difference in 1974 between the two methods was 12.35 inches. In 1975, it dropped back to 8.34 inches as the tree canopy increased in size.

The greatest water use normally occurs in the third quarter, July to September, when the highest temperatures prevail. That pattern held in all years for both methods of irrigation except for drip irrigation in 1975, when the fourth quarter slightly exceeded the third because drip irrigation was continued until the rainfall exceeded 3 inches. This relates to a peculiarity of drip irrigation on a salt-sensitive perennial crop such as avocados. When fall rains arrive, the first two inches can be hazardous. Salt that has accumulated in the surface soil around drip-irrigated trees (see Chapter 2) is washed down by early rains into the concentrated root zone where it can be damaging. The greatest problem occurs when about one inch of fall rain is received that is not followed for some time by additional rains. Such a problem occurred in the

TABLE 1.  
Canopy Size of Avocado Trees, 1971-76

Year	Height (feet)	Width (feet)
1971	3.8	1.8
1972	6.2	4.5
1973	8.9	7.8
1974	11.7	10.4
1975	12.3	10.6
1976	13.6	11.3

TABLE 2.  
Water Applied Under Drip and Sprinkler Irrigation

Year	Water applied (acre-in/acre)		Rainfall (inches)	Pan evaporation (inches)
	sprinkler	drip		
1971	8.1	4.0	9.9	—
1972	13.7	8.2	8.6	—
1973	19.2	14.5	11.3	61.6
1974	31.0	17.7	8.5	61.6
1975	32.6	24.2	10.6	58.7
1976 (to July)	13.2	8.9	8.2	31.1

experiment in the fall of 1974 and produced more than usual tip burn. It led to the conclusion that drip irrigation should be continued after fall rains start until at least two to three inches of rain have fallen.

Drip irrigation wets a smaller soil volume than sprinkling and, therefore, provides less water in storage to protect a tree from unusual demands. Because water should be applied daily, it is customary for irrigation system designers to think about the maximum potential daily requirements when planning system capacity. With some soil water storage capacity available, it is probably safe to consider maximum use on a peak-week basis rather than a single peak day. Average daily use observed for the peak week is shown in Table 3. The irrigation scheduling for both the sprinkler and drip plots were based solely on interpretation of tensiometer readings.

Fertilization with nitrogen began during the first month after planting. Regular additions of nitrogen fertilizer were made thereafter. Drip irrigated trees received the same quantity of nitrogen, applied by hand twice monthly around the drip line of each tree. During the course of the experiment three forms of nitrogen were applied: urea, calcium nitrate, and ammonium nitrate.

Soil pH, which ranged from 6.2 to 7.0 initially, was checked annually. Under the urea fertilization program, it decreased to less than 5 in some portions of the root zone. To counter this trend, calcium nitrate was substituted for urea in 1972. After the change was made, noticeably more salt accumulated at the soil surface in the drip irrigated plots. However, salinity in the root zone, which will be discussed later, was similar to that found

in previous years. In 1974, after the excess soil acidity problem was corrected, ammonium nitrate was substituted for calcium nitrate. The soil pH remained in the range of 6 to 7 thereafter.

The only element used in the fertilization program, besides nitrogen, was zinc, which was first applied as a chelate in the irrigation water in April 1972, and subsequently as a standard zinc sulfate foliar spray once each year in early summer.

Soluble salt accumulation in the soil and chloride accumulation in both the soil and leaves were monitored to determine if there were any differences associated with the two irrigation methods. The soil was initially analyzed when the orchard was established. Samples were taken from 0 to 1 foot and 1 to 2 foot depths at two sites in each of the eight plots. In no case did the soluble salts, as measured by electrical conductivity and chloride concentration of the saturation extract, exceed maximum safe levels for avocados on Mexican rootstock, i.e., 2 millimhos and 5 meq/l, respectively.

Soil salinity was determined on a regular basis thereafter, samples being taken twice each year from around the drip line of the same trees at the end of the winter rains and again at the end of the irrigation season. Six tree sites, three in drip-irrigated plots and three in sprinkler-irrigated plots, were sampled by 6- or 12-inch increments to 3 feet, the maximum soil depth in most of the orchards.

Leaf samples taken for chloride analysis were collected from two varieties in each plot in September or October, starting in 1971.

Soil chloride levels and soil salinity levels measured from the fall of 1970 through the spring of 1976 are shown in Table 4. The values are averages of the surface to 3-foot depth for all trees sampled for each irrigation method. Under both methods chloride concentration in the root zone increased during each irrigation season and then decreased as a result of leaching during the winter rainfall. The degree of winter leaching varies in San Diego County because of variability in the distribution and amount of rainfall.

Under drip irrigation, salts were highest in the first foot of soil and decreased to approximately constant but marginal levels in the 1- to 2-foot and 2- to 3-foot depths. Under sprinkler irrigation, marginal levels of salts were rather uniformly distributed throughout the 3-foot depth. That pattern prevailed in the fall for chloride and total soluble salts.

Both soil and leaf analyses indicated that the amount of water applied was not sufficient for complete salinity control under either drip or sprinkler irrigation. Duration of irrigation was then increased, starting in 1974, to achieve more leaching for salinity control.

TABLE 3.  
Daily Water Use During the Peak Week for Drip Plots

Year	Week	Gal/Tree/Day	Acre-In/Acre
1970	8/14-8/21	2.27	0.012
1971	7/16-7/23	3.62	0.019
1972	9/01-9/08	9.99	0.053
1973	8/31-9/07	18.14	0.097
1974	8/09-8/16	21.36	0.114
1975	9/12-9/19	30.21	0.162

TABLE 4.  
Soil Chloride and Salinity in Avocados

		Soil chloride (meq/l)		Soil salinity (EC × 10 <sup>3</sup> )	
		sprinkler	drip	sprinkler	drip
1970	fall	3.6	3.6	1.4	1.8
1971	spring	1.9	2.1	1.3	1.8
1971	fall	4.9	6.4	2.9	3.6
1972	spring	3.9	3.4	2.0	1.8
1972	fall	8.6	6.6	3.2	2.8
1973	spring	5.6	5.3	2.0	2.0
1973	fall	7.9	8.5	2.4	2.1
1974	spring	7.4	6.4	3.2	1.9
1975	spring	3.4	3.7	1.5	1.2
1975	spring	4.5	3.8	1.7	1.3

# References

- American Water Works Association  
1972. Standard for filtering material. January.
- Bernstein, L. and L. E. Francois  
1973. Comparisons of drip, furrow, and surface irrigation. *Soil Science* **115**:73-86.
- Bresler, E.  
1977. Trickle-drip irrigation: principles and application to soil water management. *Advances in Agronomy* **29**:343-93.
- Christiansen, J. E.  
1942. Irrigation by sprinkling. University of California Experiment Station Bulletin Number 670. 124 pp.
- Fereres, E., J. L. Meyer, F. K. Aljibury, H. Schulbach, A. W. Marsh, and A. D. Reed  
1978. Irrigation costs. University of California, Leaflet 2875. 15 pp.
- Ford, H. W.  
1977. The importance of water quality in drip/trickle irrigation systems. *Proc. Int. Soc. Citriculture* **1**:84-87.
- Ford, H. W.  
1977. A method for estimating chlorine requirements. *Proc. Fla. State Hort Soc.* **89**, 1976 (Rev): 21-23.
- Ford, H. W.  
1978. Bacterial clogging in low pressure irrigation systems. *The Irrigation Association. Technical Conference Proceedings*: 239-44.
- Goldberg, S. D. and M. Schmueli  
1970. Drip irrigation—a method used under arid and desert conditions of high water and soil salinity. *Transactions American Society of Agricultural Engineers* **13**:38-41.
- Keller, Jack, and David Karmeli  
1974. Trickle irrigation design. Rainbird Sprinkler Manufacturing Corporation. Glendora, CA.
- Lange, A., F. Aljibury, B. Fischer, W. Humphrey, and H. Otto  
1974. Weed control under drip irrigation in orchard and vineyard crops. *Second International Drip Irrigation Congress Proceedings*, San Diego, 422-24.
- Marsh, A. W.  
1978. Questions and answers about tensiometers. University of California, Leaflet 2264. 12 pp.
- Merriam, J. L., and Jack Keller  
1978. Farm irrigation system evaluation: a guide for management. Utah State University, Logan, Utah.
- Meyer, J. L. and F. K. Aljibury  
1977 (Revised). Low-head irrigation pipe: concrete, asbestos-lined, plastic. University of California, Leaflet 2908. 12 pp.
- Phene, C. J., and O. W. Beale  
1976. High-frequency irrigation for water nutrient management in humid regions. *Soil Science Society of America Proceedings*. **40**:430-36.
- Pruitt, W. O., S. Von Oettingen, and D. L. Morgan  
1972. Central California Evaporation Frequencies. *Journal of Irrigation and Drainage Division*, ASCE **98** (IR2): 177-84.
- Rauschkolb, R. S., D. E. Rolston, R. J. Miller, A. B. Carlton, and R. G. Burau  
1976. Phosphorus fertilization with drip irrigation. *Soil Science Society of America Journal*. **40**:68-72.
- Rolston, D. E., R. S. Rauschkolb, C. J. Phene, R. J. Miller, K. Uriu, R. M. Carlson, and D. W. Henderson  
1979. Applying nutrients and other chemicals to trickle-irrigated crops. University of California, Bulletin 1893. 14 pp.
- Schulbach, H.  
1975. Fertilizer injection with pressure differential systems. *Soil and Water Newsletter*. **25**: 1-4.
- U.S. Salinity Laboratory Staff, ARS, USDA  
1977. Minimizing salt in irrigation return flow through irrigation management. U.S.E.P.A. 600/2-77-134, July. 89-104.
- Uriu, K., R. M. Carlson, and D. W. Henderson  
1977. Application of potassium fertilizer to prunes through a drip irrigation system. *Seventh International Agricultural Plastics Congress Proceedings*, San Diego, CA 211-14.
- Uriu, K., R. M. Carlson, D. W. Henderson, H. Schulbach, and T. Aldrich  
1979. Getting potassium into prunes. 1979 California Plant and Soil Conference, Calif. Chapter American Society of Agronomy, San Diego. 32-3.
- Wilson, D. L.  
1977. Filtration in drip irrigation. *Proc. VII Int. Agr. Plastics Congress*. 160-65.
- Wu, I-Pai, and H. M. Gitlin  
1973. Design of drip irrigation lines. *Tech. Bulletin No. 96*, Hawaii Agricultural Experiment Station, University of Hawaii.
- Wu, I-Pai, and H. M. Gitlin  
1974. Lateral and submain design for a drip irrigation system. *The Engineer's Notebook—April 1974*. Cooperative Extension Service, University of Hawaii. No. 13.
- Wu, I-Pai, and H. M. Gitlin  
1975. Energy gradient line for drip irrigation laterals. *Journal of the Irrigation and Drainage Division*, ASCE. **101**: (4)321-26.